

Braced Post Insulator Assembly B2901053T12083MA

1) H2 90 10 043 MX SS 022	[1]
2) S1 40 80 042 MA AL 027	[1]
3) Socket/Y-Clevis (SYC-56)	[1]
4) Turnbuckle (G-227-NBC-3/4x12C)	[1]
5) Shackle (ASH-55-BC)	[1]

ASSEMBLY DIMENSIONAL VALUES

Post Section Length (PSL)	53.3 in	1,354 mm
Suspension Section Length (SSL)	54.0 in	1,372 mm
Height of Assembly (H)	83.0 in	2,108 mm
Length of Brace (B)	87.2 in	2,215 mm
Upper Pole Connection Offset (A)*	2.0 in	51 mm
Angle Between Insulators (C)		66 Degrees
Dry Arc Distance	41.5 in	1,054 mm
Leakage Distance	116.7 in	2,964 mm

*This connection bracket to be supplied by customer

ASSEMBLY ELECTRICAL VALUES*

60 Hz Dry F.O. (Min. Withstand)	398 kV	(373) kV
60 Hz Wet F.O. (Min. Withstand)	368 kV	(289) kV
CIFO+ (Min. Withstand)	685 kV	(612) kV
CIFO- (Min. Withstand)	763 kV	(650) kV

*Values shown are based on minimum electricals for the assembly

ASSEMBLY MECHANICAL VALUES

Maximum Working Vertical Load	11,718 lbs	52.1 kN
-------------------------------	------------	---------

This drawing contains confidential information that is the property of MacLean Power, L.L.C. ("MacLean"). Use of MacLean's confidential information without MacLean's express written consent is strictly prohibited and may expose you to legal liability. If you believe that you received this material in error, please destroy it or return it to "MacLean Power, L.L.C., 7801 Park Place Rd., York, South Carolina 29745, USA."

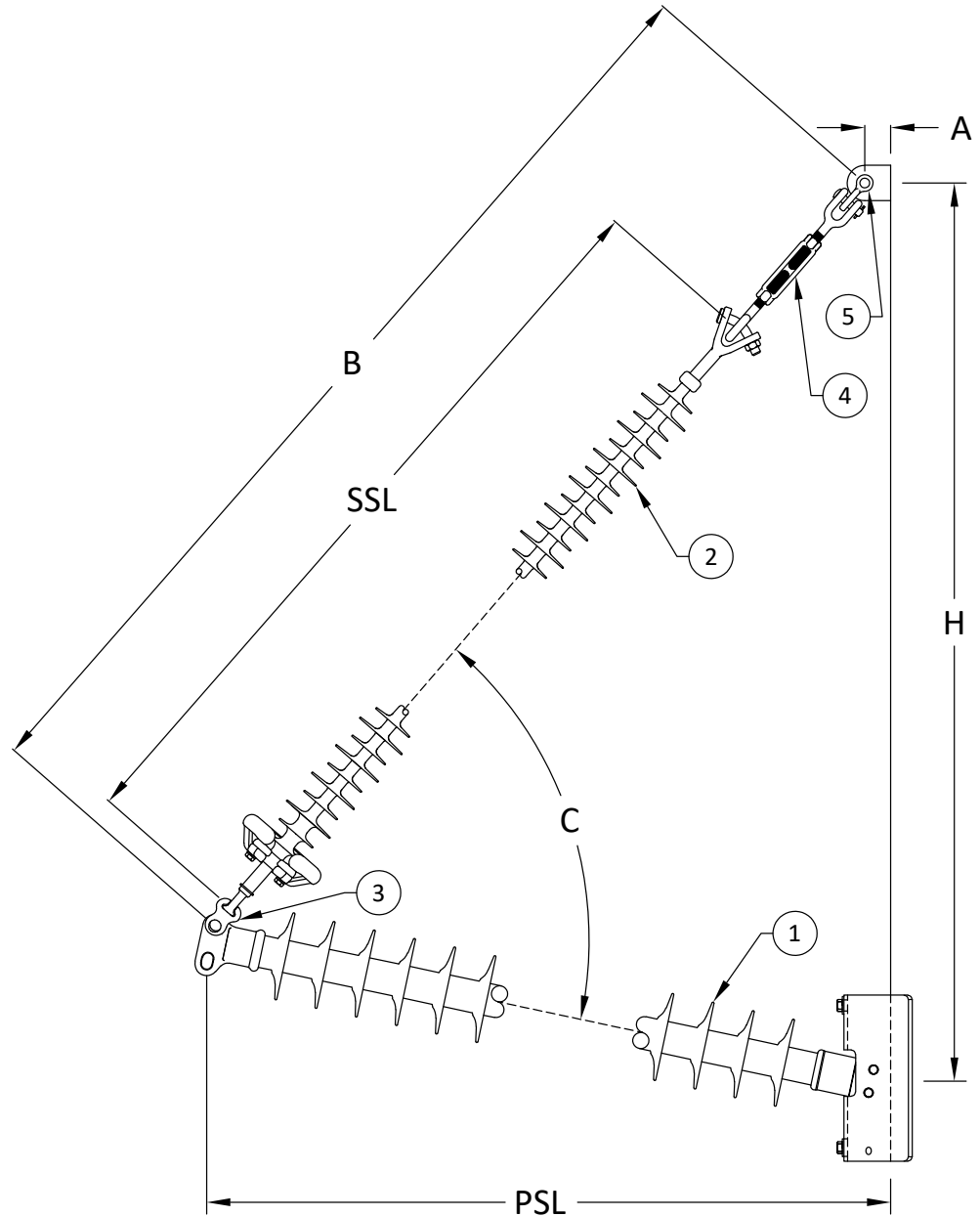

MPS Catalog Number

H2 90 10 043 MX SS 022

Date: 03/24/2022

End Fittings

Tower End Fitting:

Gain / 12 deg / Steel

Line End Fitting:

2 HL Drop Tongue / Galv. Ductile Iron

Material

Corona Ring (Line):

None

Corona Rings are recommended for applications of 230 kV and above

Mounting Angle:

12 deg

Number of Sheds:

22

Rod Diameter:

2.5 in

Weight Estimate:

57.9 lbs

26 kg

Dimensional Values

Section Length (L):

53.3 in 1,354 mm

Rubber Length (X):

43 in 1,092 mm

Shed spacing (S):

1.95 in 50 mm

Shed Projection (P):

1.86 in 47 mm

Dry Arc Distance:

45.1 in 1,145 mm

Leakage Distance:

116.7 in 2,965 mm

Electricals Values

60 Hz dry Flashover (Min. Withstand):

429 kV 403 kV

60 Hz Wet Flashover (Min. Withstand):

398 kV 313 kV

CIFO Positive (Min. Withstand):

742 kV 662 kV

CIFO Negative (Min. Withstand):

809 kV 701 kV

Mechanical Values

Max. Design Cant. Load (MDCL):

1,748 lbs 7.8 kN

Specified Cant. Load (SCL):

3,496 lbs 15.6 kN

Specified Tensile Load (STL):

15,000 lbs 66.7 kN

This drawing contains confidential information that is the property of MacLean Power, L.L.C. ("MacLean"). Use of MacLean's confidential information without MacLean's express written consent is strictly prohibited and may expose you to legal liability. If you believe that you received this material in error, please destroy it or return it to "MacLean Power, L.L.C., 7801 Park Place Rd., York, South Carolina 29745, USA."

Notes:

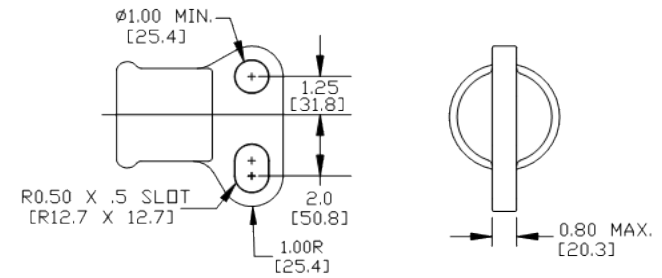
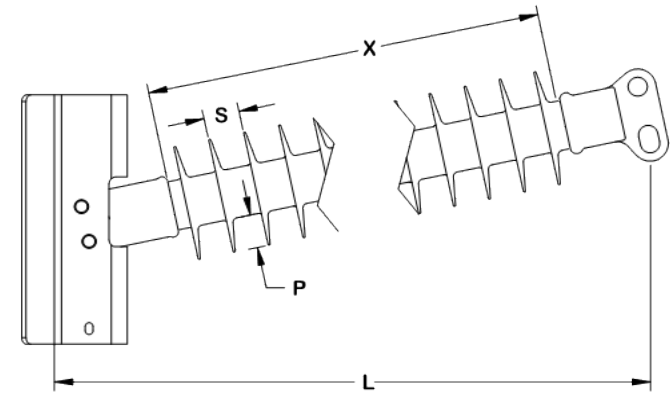
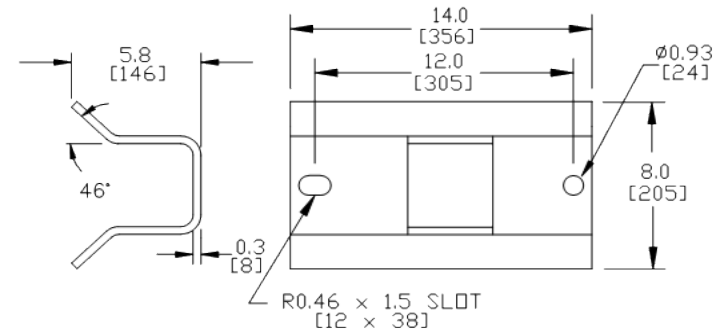

Dimension: inches [millimeters]

NOTE: Drawing not actual depiction of insulator appearance.

Silicone rubber sheath and sheds complies with applicable ANSI and IEC standards.

Prepared By: Stephen Lucci

MPS Catalog Number

S1 40 80 042 MA AL 027

Date: 04/01/2022

End Fittings

Tower End Fitting:

Y-Clevis / Forged Steel

Line End Fitting:

Ball / Forged Steel
/ (ANSI 52-5)

Material

Corona Ring (Line):

8" Corona Ring

Corona Rings are recommended for applications of 230 kV and above

Number of Sheds:

13 large 14 standard

Rod Diameter:

16 mm

Weight Estimate:

12.1 lbs 6 kg

Dimensional Values

Section Length (L):

54 in 1,372 mm

Rubber Length (X):

42 in 1,067 mm

Standard Shed Height (P1):

1.5 in 38 mm

Large Shed Height (P2):

2 in 51 mm

Projection Ration (S/P):

- 1.5

Shed Spacing (S):

3 in 76 mm

Dry Arc Distance:

42.2 in 1,072 mm

Leakage Distance:

121.8 in 3,094 mm

Electricals Values

60 Hz dry Flashover (Min. Withstand):

416 kV 386 kV

60 Hz Wet Flashover (Min. Withstand):

374 kV 325 kV

CIFO Positive (Min. Withstand):

716 kV 620 kV

CIFO Negative (Min. Withstand):

761 kV 666 kV

Mechanical Values

Specified Mech. Load (SML):

25,000 lbs 111.2 kN

Routine Test Load (RTL):

12,500 lbs 55.6 kN

This drawing contains confidential information that is the property of MacLean Power, L.L.C. ("MacLean"). Use of MacLean's confidential information without MacLean's express written consent is strictly prohibited and may expose you to legal liability. If you believe that you received this material in error, please destroy it or return it to "MacLean Power, L.L.C., 7801 Park Place Rd., York, South Carolina 29745, USA."

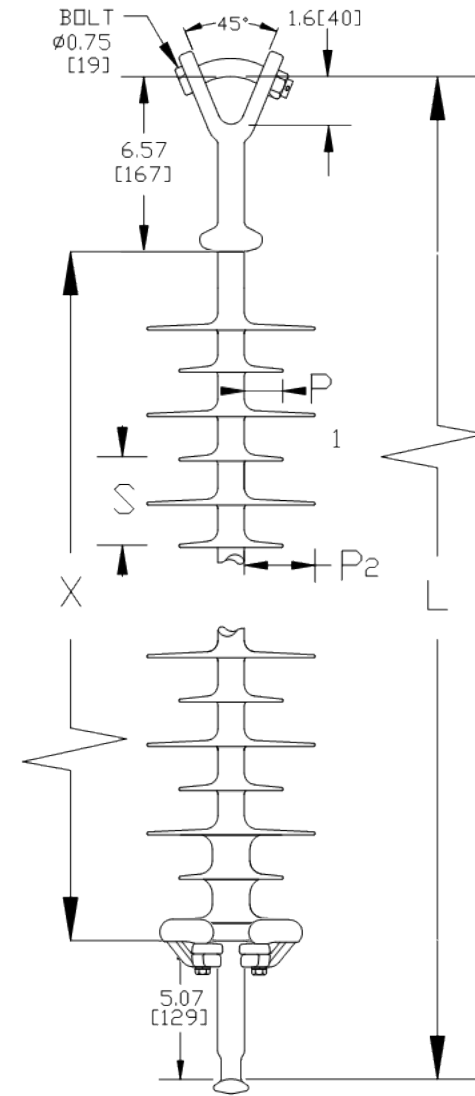

Dimension: inches [millimeters]

NOTE: Drawing not actual depiction of insulator appearance.

Silicone rubber sheath and sheds complies with applicable ANSI and IEC standards.

Notes:

Prepared By: Stephen Lucci



MacLean Power Systems

B2901053T12083MA Ultimate Combined Load Curve

Factor of Safety = 1



Assumptions:
-Loading sequence is Longitudinal, Vertical, Transverse
-Factor of Safety applied to entire system
-Negligible downward tip deflection
-Static moduli values
-Confidence level of 95%

