

## Braced Post Insulator Assembly B2901060T12075MA

1) H2 90 10 050 MX SS 026	[1]
2) S1 40 80 048 MA AL 031	[1]
3) Socket/Y-Clevis (SYC-56)	[1]
4) Turnbuckle (G-227-NBC-3/4x6C)	[1]
5) Shackle (ASH-55-BC)	[1]

### ASSEMBLY DIMENSIONAL VALUES

Post Section Length (PSL)	60.1 in	1,527 mm
Suspension Section Length (SSL)	60.0 in	1,524 mm
Height of Assembly (H)	75.0 in	1,905 mm
Length of Brace (B)	84.1 in	2,136 mm
Upper Pole Connection Offset (A)*	2.0 in	51 mm
Angle Between Insulators (C)		59 Degrees
Dry Arc Distance	47.7 in	1,212 mm
Leakage Distance	137.9 in	3,503 mm

\*This connection bracket to be supplied by customer

### ASSEMBLY ELECTRICAL VALUES\*

60 Hz Dry F.O. (Min. Withstand)	453 kV	(425) kV
60 Hz Wet F.O. (Min. Withstand)	419 kV	(331) kV
CIFO+ (Min. Withstand)	784 kV	(698) kV
CIFO- (Min. Withstand)	842 kV	(738) kV

\*Values shown are based on minimum electricals for the assembly

### ASSEMBLY MECHANICAL VALUES

Maximum Working Vertical Load	10,949 lbs	48.7 kN
-------------------------------	------------	---------

This drawing contains confidential information that is the property of MacLean Power, L.L.C. ("MacLean"). Use of MacLean's confidential information without MacLean's express written consent is strictly prohibited and may expose you to legal liability. If you believe that you received this material in error, please destroy it or return it to "MacLean Power, L.L.C., 7801 Park Place Rd., York, South Carolina 29745, USA."

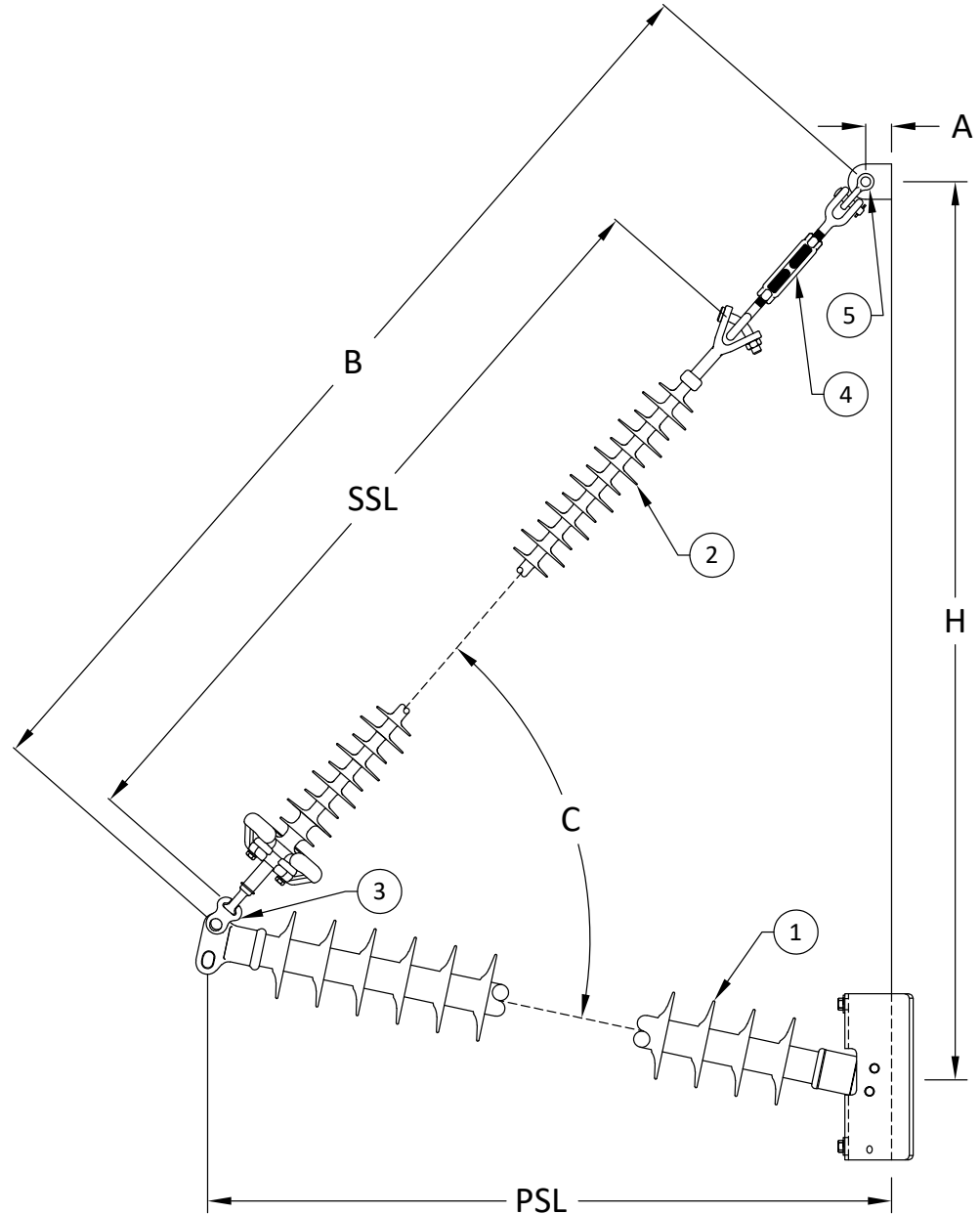

MPS Catalog Number

**H2 90 10 050 MX SS 026**

Date: 03/25/2022

**End Fittings**

Tower End Fitting:

Gain / 12 deg / Steel

Line End Fitting:

2 HL Drop Tongue / Galv. Ductile Iron

**Material**

Corona Ring (Line):

None

Corona Rings are recommended for applications of 230 kV and above

Mounting Angle:

12 deg

Number of Sheds:

26

Rod Diameter:

2.5 in

Weight Estimate:

62.4 lbs

28 kg

**Dimensional Values**

Section Length (L):

60.1 in 1,527 mm

Rubber Length (X):

50 in 1,270 mm

Shed spacing (S):

1.95 in 50 mm

Shed Projection (P):

1.86 in 47 mm

Dry Arc Distance:

52.9 in 1,343 mm

Leakage Distance:

137.9 in 3,503 mm

**Electricals Values**

60 Hz dry Flashover (Min. Withstand):

498 kV 468 kV

60 Hz Wet Flashover (Min. Withstand):

461 kV 365 kV

CIFO Positive (Min. Withstand):

866 kV 769 kV

CIFO Negative (Min. Withstand):

912 kV 811 kV

**Mechanical Values**

Max. Design Cant. Load (MDCL):

1,520 lbs 6.8 kN

Specified Cant. Load (SCL):

3,040 lbs 13.5 kN

Specified Tensile Load (STL):

15,000 lbs 66.7 kN

This drawing contains confidential information that is the property of MacLean Power, L.L.C. ("MacLean"). Use of MacLean's confidential information without MacLean's express written consent is strictly prohibited and may expose you to legal liability. If you believe that you received this material in error, please destroy it or return it to "MacLean Power, L.L.C., 7801 Park Place Rd., York, South Carolina 29745, USA."

Notes:

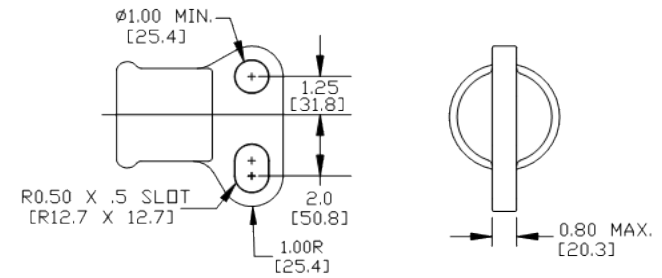
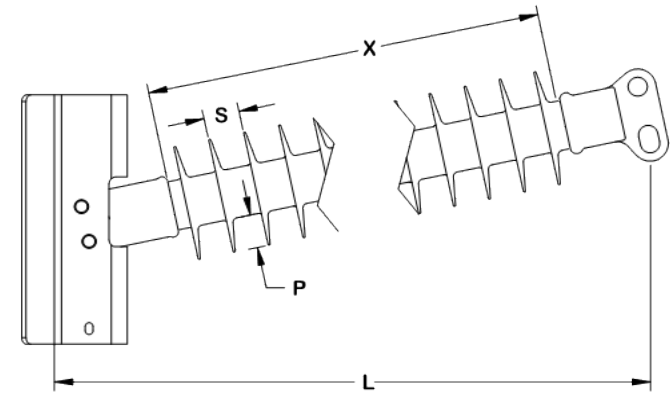
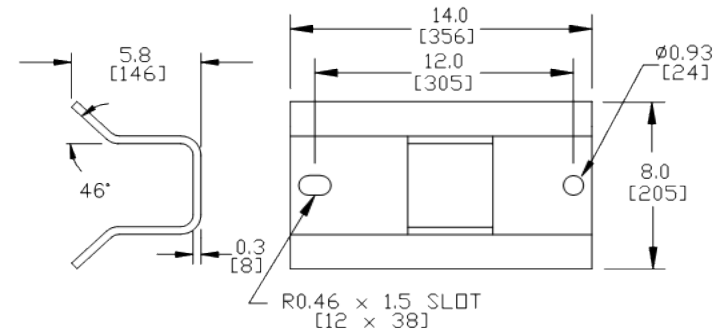

Dimension: inches [millimeters]

NOTE: Drawing not actual depiction of insulator appearance.

Silicone rubber sheath and sheds complies with applicable ANSI and IEC standards.

Prepared By: Stephen Lucci

MPS Catalog Number

**S1 40 80 048 MA AL 031**

Date: 04/01/2022

**End Fittings**

Tower End Fitting:

Y-Clevis / Forged Steel

Line End Fitting:

Ball / Forged Steel  
/ (ANSI 52-5)

**Material**

Corona Ring (Line):

8" Corona Ring

Corona Rings are recommended for applications of 230 kV and above

Number of Sheds:

15 large      16 standard

Rod Diameter:

16 mm

Weight Estimate:

12.9 lbs      6 kg

**Dimensional Values**

Section Length (L):

60 in      1,524 mm

Rubber Length (X):

48 in      1,219 mm

Standard Shed Height (P1):

1.5 in      38 mm

Large Shed Height (P2):

2 in      51 mm

Projection Ration (S/P):

-      1.5

Shed Spacing (S):

3 in      76 mm

Dry Arc Distance:

48.1 in      1,222 mm

Leakage Distance:

140.1 in      3,559 mm

**Electricals Values**

60 Hz dry Flashover (Min. Withstand):

472 kV      437 kV

60 Hz Wet Flashover (Min. Withstand):

422 kV      367 kV

CIFO Positive (Min. Withstand):

809 kV      703 kV

CIFO Negative (Min. Withstand):

857 kV      751 kV

**Mechanical Values**

Specified Mech. Load (SML):

25,000 lbs      111.2 kN

Routine Test Load (RTL):

12,500 lbs      55.6 kN

Notes:

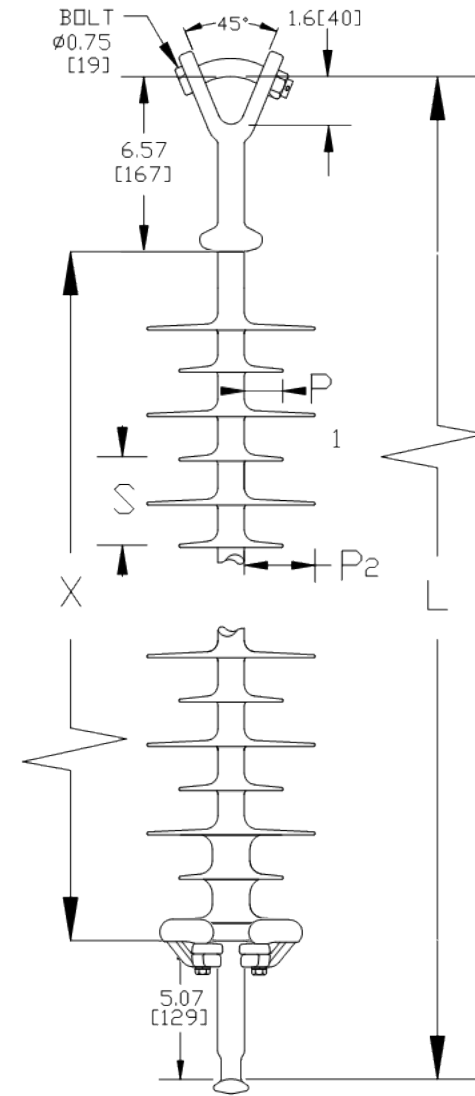

Dimension: inches [millimeters]

NOTE: Drawing not actual depiction of insulator appearance.

Silicone rubber sheath and sheds complies with applicable ANSI and IEC standards.

Prepared By: Stephen Lucci



MacLean Power Systems

## B2901060T12075MA Ultimate Combined Load Curve

Factor of Safety = 1

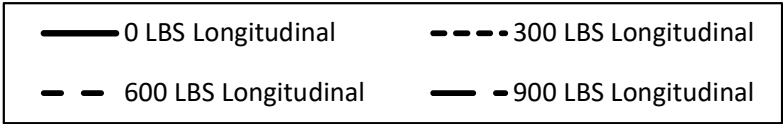

**Assumptions:**  
-Loading sequence is Longitudinal, Vertical, Transverse  
-Factor of Safety applied to entire system  
-Negligible downward tip deflection  
-Static moduli values  
-Confidence level of 95%

