

Braced Post Insulator Assembly B2901099T12100AA

1) H2 90 10 090 AX SS 035	[1]
2) S1 40 80 079 VA SS 043	[1]
3) Socket/Y-Clevis (SYC-56)	[1]
4) Turnbuckle (G-227-NBC-3/4x12C)	[1]
5) Shackle (ASH-55-BC)	[1]

ASSEMBLY DIMENSIONAL VALUES

Post Section Length (PSL)	99.3 in	2,522 mm
Suspension Section Length (SSL)	90.6 in	2,301 mm
Height of Assembly (H)	100.0 in	2,540 mm
Length of Brace (B)	124.3 in	3,157 mm
Upper Pole Connection Offset (A)*	2.0 in	51 mm
Angle Between Insulators (C)		51 Degrees
Dry Arc Distance	79.0 in	2,007 mm
Leakage Distance	244.6 in	6,213 mm

*This connection bracket to be supplied by customer

ASSEMBLY ELECTRICAL VALUES*

60 Hz Dry F.O. (Min. Withstand)	724 kV	(679) kV
60 Hz Wet F.O. (Min. Withstand)	658 kV	(533) kV
CIFO+ (Min. Withstand)	1,271 kV	(1,119) kV
CIFO- (Min. Withstand)	1,297 kV	(1,170) kV

*Values shown are based on minimum electricals for the assembly

ASSEMBLY MECHANICAL VALUES

Maximum Working Vertical Load	9,927 lbs	44.2 kN
-------------------------------	-----------	---------

This drawing contains confidential information that is the property of MacLean Power, L.L.C. ("MacLean"). Use of MacLean's confidential information without MacLean's express written consent is strictly prohibited and may expose you to legal liability. If you believe that you received this material in error, please destroy it or return it to "MacLean Power, L.L.C., 7801 Park Place Rd., York, South Carolina 29745, USA."

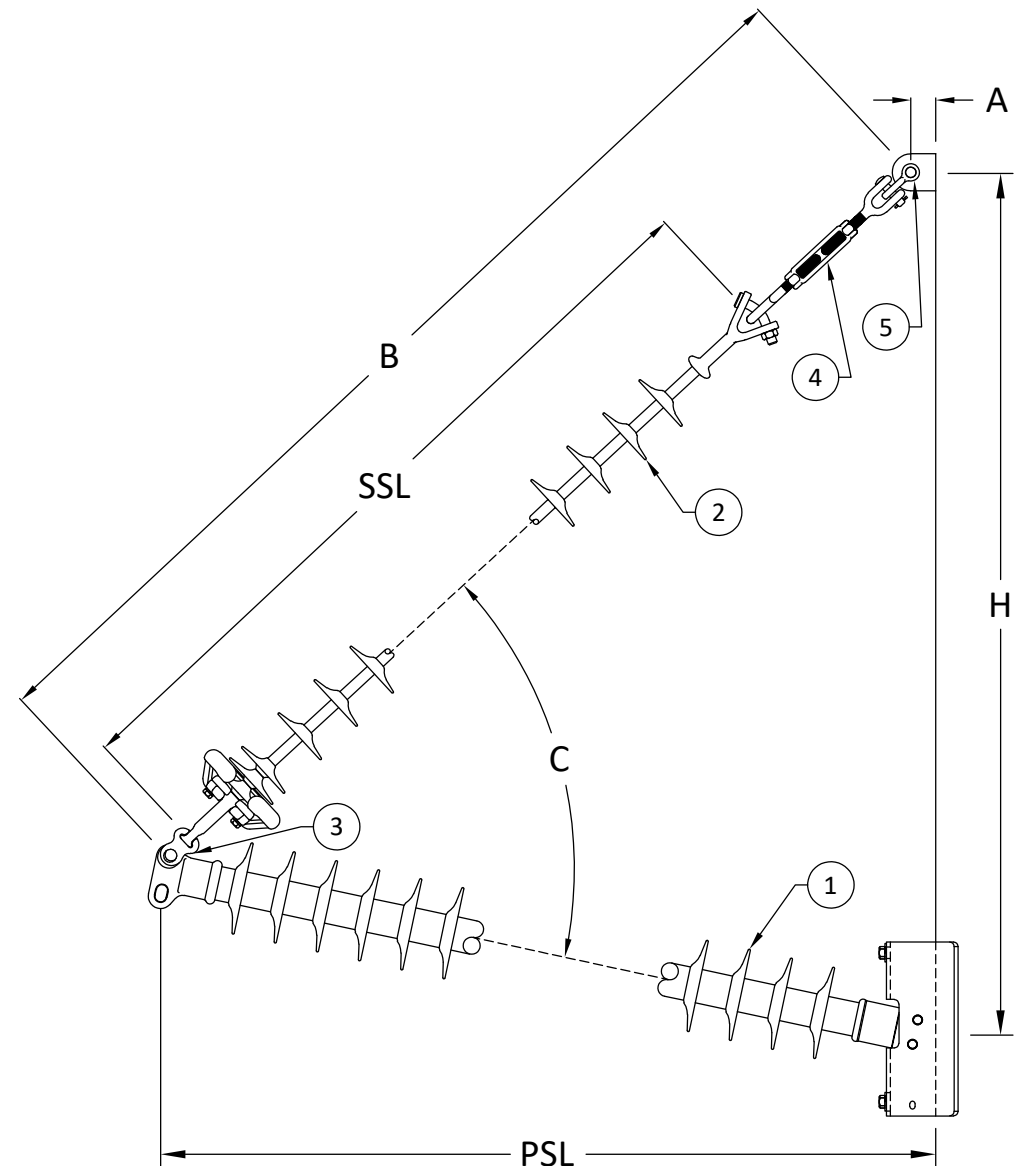

MPS Catalog Number:

Date:

H2 90 10 090 AX SS 035

04/11/2022

End Fittings

Tower End Fitting:

Gain / 12 deg / Steel

Line End Fitting:

Anchor / Ductile Iron
2 HL Drop Tongue / Galv. Ductile Iron

Material

Corona Ring (Tower):

None

Corona Ring (Line):

None

Corona Rings are recommended for applications of 230 kV and above

Mounting Angle:

12 deg

Number of Sheds:

35

Rod Diameter:

2.5 in

Weight Estimate:

101.7 lbs

46 kg

Dimensional Values

Section Length (L):

99.3 in 2,522 mm

Rubber Length (X):

90 in 2,286 mm

Shed spacing (S):

2.5 in 64 mm

Shed Projection (P):

2.4 in 61 mm

Dry Arc Distance:

92.9 in 2,360 mm

Leakage Distance:

247.5 in 6,287 mm

Electricals Values

60 Hz dry Flashover (Min. Withstand):

840 kV 789 kV

60 Hz Wet Flashover (Min. Withstand):

755 kV 618 kV

CIFO Positive (Min. Withstand):

1478 kV 1299 kV

CIFO Negative (Min. Withstand):

1496 kV 1356 kV

Mechanical Values

Max. Design Cant. Load (MDCL):

885 lbs 3.9 kN

Specified Cant. Load (SCL):

1,770 lbs 7.9 kN

Specified Tensile Load (STL):

15,000 lbs 66.7 kN

This drawing contains confidential information that is the property of MacLean Power, L.L.C. ("MacLean"). Use of MacLean's confidential information without MacLean's express written consent is strictly prohibited and may expose you to legal liability. If you believe that you received this material in error, please destroy it or return it to "MacLean Power, L.L.C., 7801 Park Place Rd., York, South Carolina 29745, USA."

Notes:

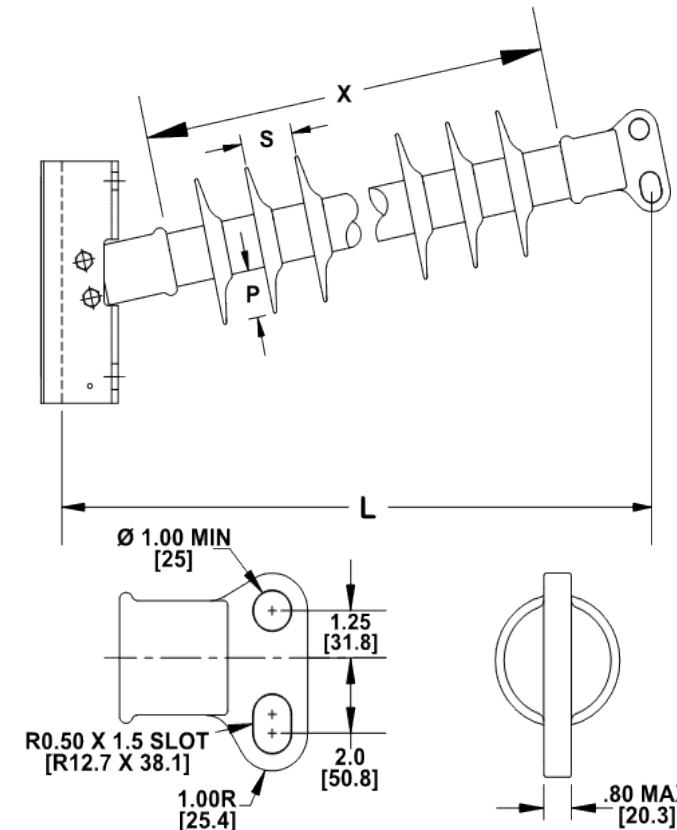
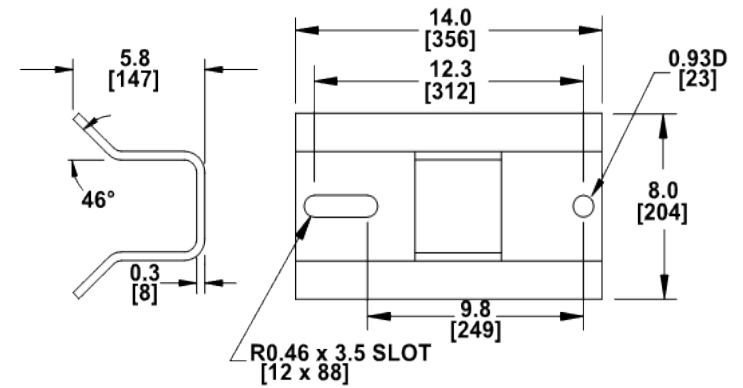

Dimension: inches [millimeters]

NOTE: Drawing not actual depiction of insulator appearance.

Silicone rubber sheath and sheds complies with applicable ANSI and IEC standards.

Prepared By: Stephen Lucci

MPS Catalog Number:

S1 40 80 079 VA SS 043

Date:

04/12/2022

End Fittings

Tower End Fitting:

Y-Clevis

Line End Fitting:

Ball (ANSI 52-5)

Material

Corona Ring (Tower):

None

Corona Ring (Line):

8" Corona Ring

Corona Rings are recommended for applications of 230 kV and above

Number of Sheds:

43 Standard

Rod Diameter:

16 mm

Weight Estimate:

20.6 lbs

9 kg

Dimensional Values

Section Length (L):

90.6 in 2,301 mm

Rubber Length (X):

79 in 2,007 mm

Standard Shed Height (P):

2.1 in 54 mm

Shed Spacing (S):

1.85 in 47 mm

Dry Arc Distance:

79 in 2,007 mm

Leakage Distance:

244.6 in 6,213 mm

Electrical Values

60 Hz dry Flashover (Min. Withstand):

767 kV 694 kV

60 Hz Wet Flashover (Min. Withstand):

658 kV 572 kV

CIFO Positive (Min. Withstand):

1277 kV 1138 kV

CIFO Negative (Min. Withstand):

1337 kV 1196 kV

Mechanical Values

Specified Mech. Load (SML):

25,000 lbs 111.2 kN

Routine Test Load (RTL):

12,500 lbs 55.6 kN

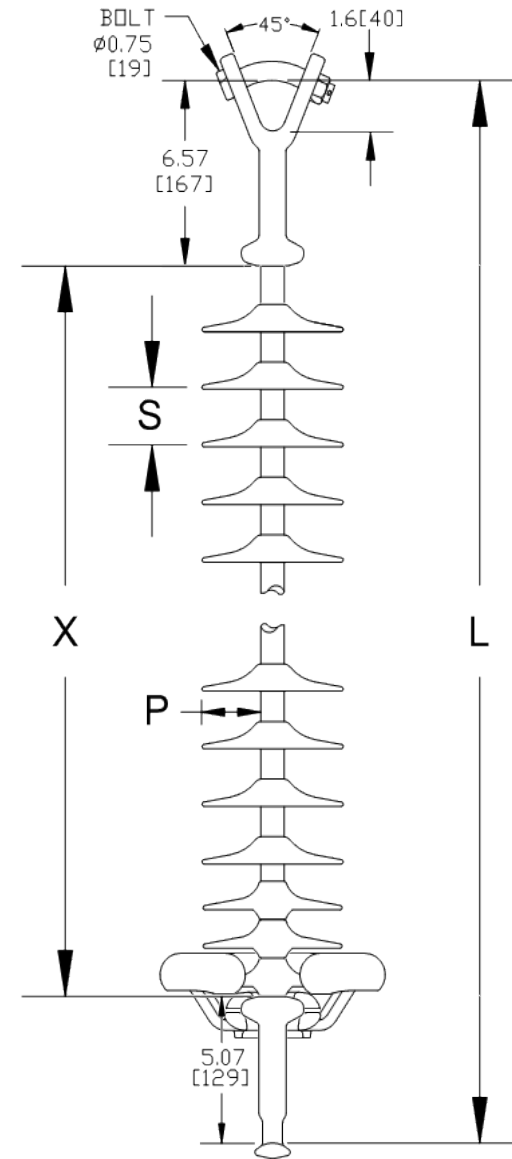

Dimension: inches [millimeters]

NOTE: Drawing not actual depiction of insulator appearance.

Silicone rubber sheath and sheds complies with applicable ANSI and IEC standards.

Notes:

Prepared By: Stephen Lucci



MacLean Power Systems

B2901099T12100AA Ultimate Combined Load Curve

Factor of Safety = 1

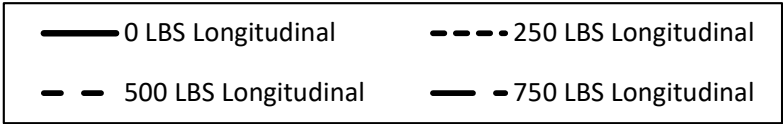

Assumptions:
-Loading sequence is Longitudinal, Vertical, Transverse
-Factor of Safety applied to entire system
-Negligible downward tip deflection
-Static moduli values
-Confidence level of 95%

