

Braced Post Insulator Assembly B2911046T12051MX

1) H2 91 10 035 MX SS 018	[1]
2) S1 40 80 031 MX AL 019	[1]
3) Socket/Y-Clevis (SYC-56)	[1]
4) Turnbuckle (G-227-NBC-3/4x6C)	[1]
5) Shackle (ASH-55-BC)	[1]

ASSEMBLY DIMENSIONAL VALUES

Post Section Length (PSL)	46.0 in	1,168 mm
Suspension Section Length (SSL)	42.2 in	1,072 mm
Height of Assembly (H)	51.0 in	1,295 mm
Length of Brace (B)	66.4 in	1,687 mm
Upper Pole Connection Offset (A)*	2.0 in	51 mm
Angle Between Insulators (C)		48 Degrees
Dry Arc Distance	32.8 in	833 mm
Leakage Distance	85.2 in	2,164 mm

*This connection bracket to be supplied by customer

ASSEMBLY ELECTRICAL VALUES*

60 Hz Dry F.O. (Min. Withstand)	320 kV	(300) kV
60 Hz Wet F.O. (Min. Withstand)	295 kV	(229) kV
CIFO+ (Min. Withstand)	547 kV	(490) kV
CIFO- (Min. Withstand)	640 kV	(526) kV

*Values shown are based on minimum electricals for the assembly

ASSEMBLY MECHANICAL VALUES

Maximum Working Vertical Load	9,363 lbs	41.6 kN
-------------------------------	-----------	---------

This drawing contains confidential information that is the property of MacLean Power, L.L.C. ("MacLean"). Use of MacLean's confidential information without MacLean's express written consent is strictly prohibited and may expose you to legal liability. If you believe that you received this material in error, please destroy it or return it to "MacLean Power, L.L.C., 7801 Park Place Rd., York, South Carolina 29745, USA."

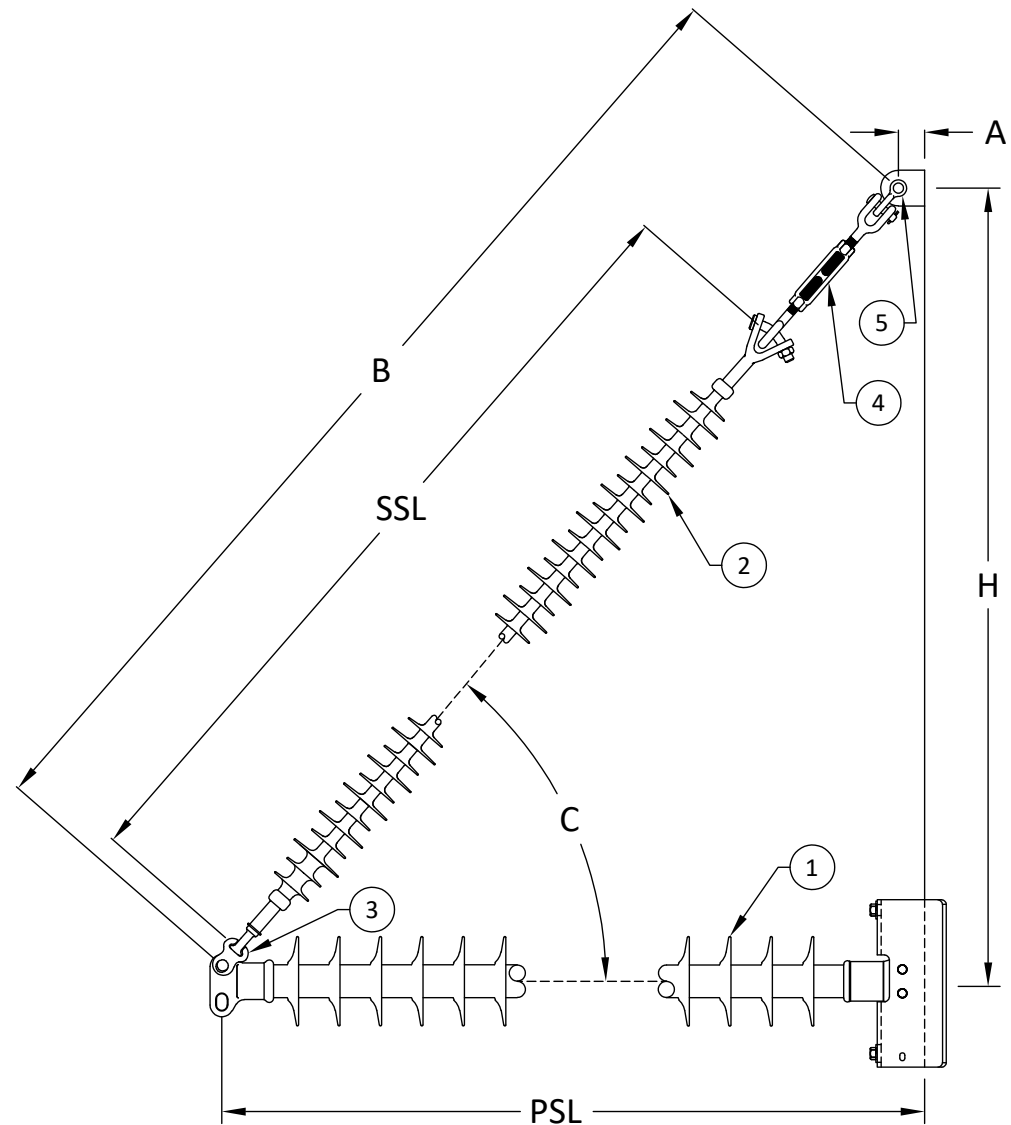

MPS Catalog Number

H2 91 10 035 MX SS 018

Date: 04/13/2022

End Fittings

Tower End Fitting:

Gain / 0 deg / Steel

Line End Fitting:

2 HL Drop Tongue / Galv. Ductile Iron

Material

Corona Ring (Line):

None

Corona Rings are recommended for applications of 230 kV and above

Mounting Angle:

0 deg

Number of Sheds:

18

Rod Diameter:

2.5 in

Weight Estimate:

53.5 lbs

24 kg

Dimensional Values

Section Length (L):

46 in 1,168 mm

Rubber Length (X):

35 in 889 mm

Shed spacing (S):

1.95 in 50 mm

Shed Projection (P):

1.86 in 47 mm

Dry Arc Distance:

37.3 in 947 mm

Leakage Distance:

95.6 in 2,427 mm

Electricals Values

60 Hz dry Flashover (Min. Withstand):

360 kV 338 kV

60 Hz Wet Flashover (Min. Withstand):

333 kV 260 kV

CIFO Positive (Min. Withstand):

618 kV 553 kV

CIFO Negative (Min. Withstand):

705 kV 590 kV

Mechanical Values

Max. Design Cant. Load (MDCL):

2,036 lbs 9.1 kN

Specified Cant. Load (SCL):

4,072 lbs 18.1 kN

Specified Tensile Load (STL):

15,000 lbs 66.7 kN

This drawing contains confidential information that is the property of MacLean Power, L.L.C. ("MacLean"). Use of MacLean's confidential information without MacLean's express written consent is strictly prohibited and may expose you to legal liability. If you believe that you received this material in error, please destroy it or return it to "MacLean Power, L.L.C., 7801 Park Place Rd., York, South Carolina 29745, USA."

Notes:

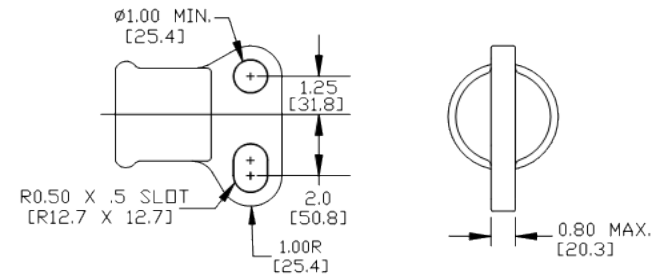
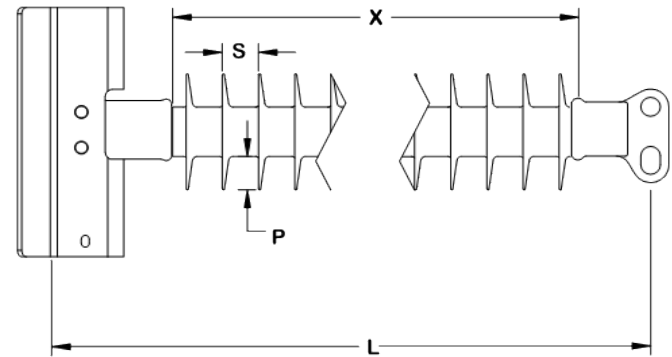
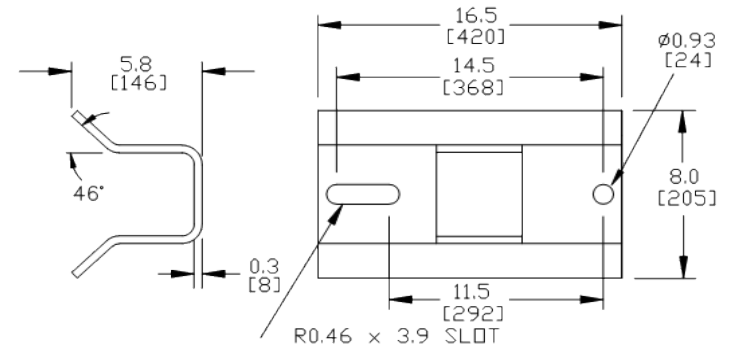

Dimension: inches [millimeters]

NOTE: Drawing not actual depiction of insulator appearance.

Silicone rubber sheath and sheds complies with applicable ANSI and IEC standards.

Prepared By: Stephen Lucci

MPS Catalog Number

S1 40 80 031 MX AL 019

Date: 03/23/2022

End Fittings

Tower End Fitting:

Y-Clevis / Forged Steel

Line End Fitting:

Ball / Forged Steel
/ (ANSI 52-5)

Material

Corona Ring (Line):

None

Corona Rings are recommended for applications of 230 kV and above

Number of Sheds:

9 large 10 standard

Rod Diameter:

16 mm

Weight Estimate:

8.2 lbs 4 kg

Dimensional Values

Section Length (L):

42.2 in 1,072 mm

Rubber Length (X):

31 in 787 mm

Standard Shed Height (P1):

1.5 in 38 mm

Large Shed Height (P2):

2 in 51 mm

Projection Ration (S/P):

- 1.5

Shed Spacing (S):

3 in 76 mm

Dry Arc Distance:

32.8 in 833 mm

Leakage Distance:

85.2 in 2,164 mm

Electricals Values

60 Hz dry Flashover (Min. Withstand):

327 kV 304 kV

60 Hz Wet Flashover (Min. Withstand):

295 kV 257 kV

CIFO Positive (Min. Withstand):

566 kV 487 kV

CIFO Negative (Min. Withstand):

605 kV 531 kV

Mechanical Values

Specified Mech. Load (SML):

25,000 lbs 111.2 kN

Routine Test Load (RTL):

12,500 lbs 55.6 kN

Notes:

This drawing contains confidential information that is the property of MacLean Power, L.L.C. ("MacLean"). Use of MacLean's confidential information without MacLean's express written consent is strictly prohibited and may expose you to legal liability. If you believe that you received this material in error, please destroy it or return it to "MacLean Power, L.L.C., 7801 Park Place Rd., York, South Carolina 29745, USA."

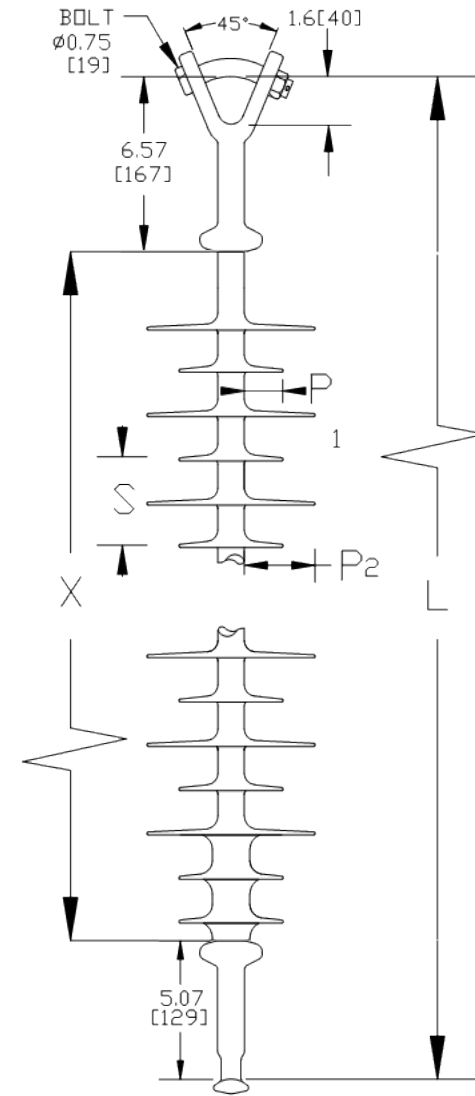

Dimension: inches [millimeters]

NOTE: Drawing not actual depiction of insulator appearance.

Silicone rubber sheath and sheds complies with applicable ANSI and IEC standards.

Prepared By: Stephen Lucci



MacLean Power Systems

B2911046T12051MX Ultimate Combined Load Curve

Factor of Safety = 1

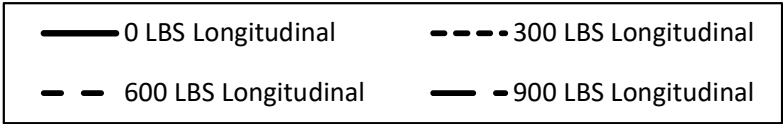

Assumptions:
-Loading sequence is Longitudinal, Vertical, Transverse
-Factor of Safety applied to entire system
-Negligible downward tip deflection
-Static moduli values
-Confidence level of 95%

