

Braced Post Insulator Assembly B2911050T12067MX

1) H2 91 10 039 MX SS 020	[1]
2) S1 40 80 037 MX AL 023	[1]
3) Socket/Y-Clevis (SYC-56)	[1]
4) Turnbuckle (G-227-NBC-3/4x12C)	[1]
5) Shackle (ASH-55-BC)	[1]

ASSEMBLY DIMENSIONAL VALUES

Post Section Length (PSL)	50.0 in	1,270 mm
Suspension Section Length (SSL)	48.2 in	1,224 mm
Height of Assembly (H)	67.0 in	1,702 mm
Length of Brace (B)	81.4 in	2,068 mm
Upper Pole Connection Offset (A)*	2.0 in	51 mm
Angle Between Insulators (C)		53 Degrees
Dry Arc Distance	38.8 in	986 mm
Leakage Distance	103.5 in	2,629 mm

*This connection bracket to be supplied by customer

ASSEMBLY ELECTRICAL VALUES*

60 Hz Dry F.O. (Min. Withstand)	374 kV	(351) kV
60 Hz Wet F.O. (Min. Withstand)	346 kV	(271) kV
CIFO+ (Min. Withstand)	643 kV	(574) kV
CIFO- (Min. Withstand)	727 kV	(612) kV

*Values shown are based on minimum electricals for the assembly

ASSEMBLY MECHANICAL VALUES

Maximum Working Vertical Load	10,096 lbs	44.9 kN
-------------------------------	------------	---------

This drawing contains confidential information that is the property of MacLean Power, L.L.C. ("MacLean"). Use of MacLean's confidential information without MacLean's express written consent is strictly prohibited and may expose you to legal liability. If you believe that you received this material in error, please destroy it or return it to "MacLean Power, L.L.C., 7801 Park Place Rd., York, South Carolina 29745, USA."

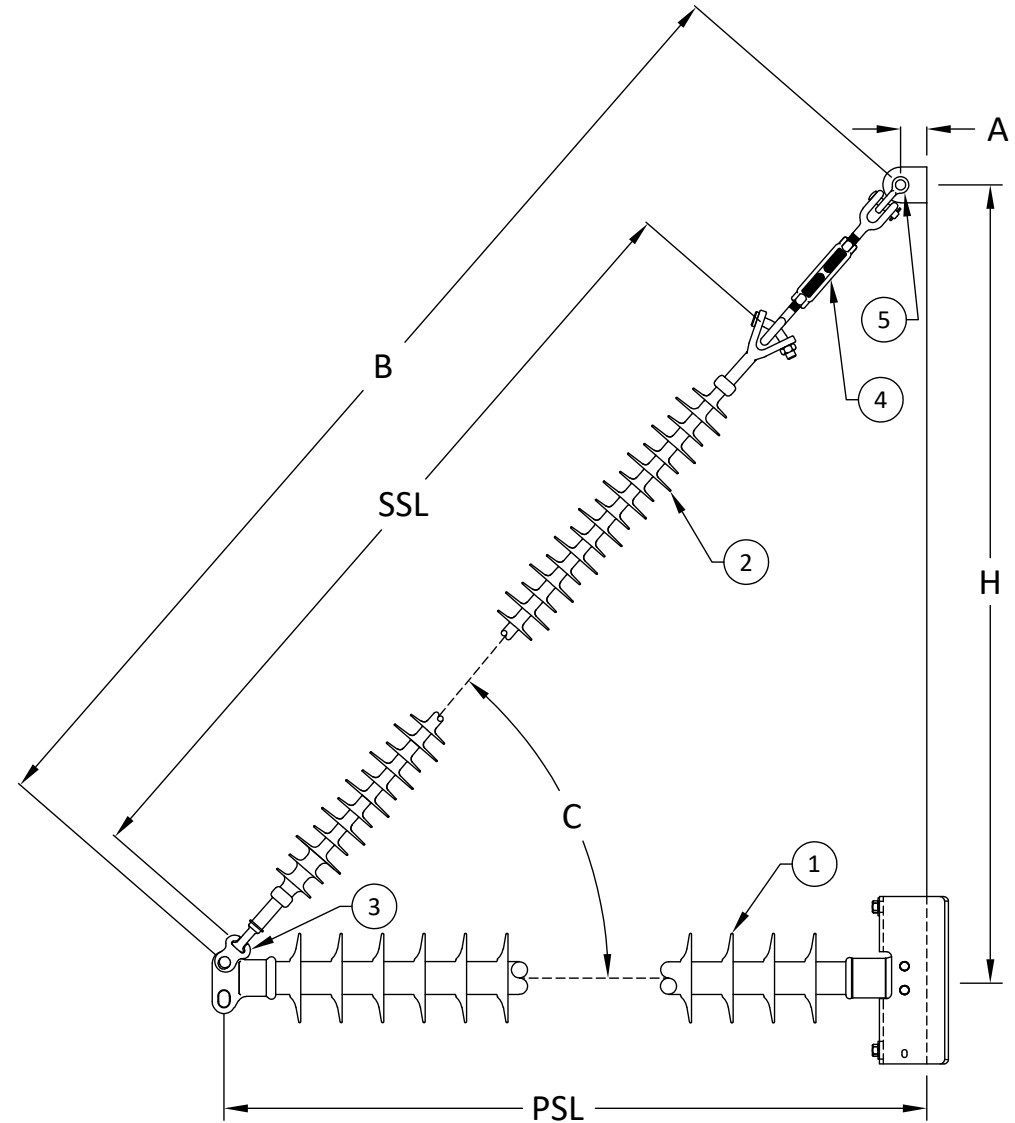

MPS Catalog Number

H2 91 10 039 MX SS 020

Date: 04/13/2022

End Fittings

Tower End Fitting:

Gain / 0 deg / Steel

Line End Fitting:

2 HL Drop Tongue / Galv. Ductile Iron

Material

Corona Ring (Line):

None

Corona Rings are recommended for applications of 230 kV and above

Mounting Angle:

0 deg

Number of Sheds:

20

Rod Diameter:

2.5 in

Weight Estimate:

55.7 lbs

25 kg

Dimensional Values

Section Length (L):

50 in 1,270 mm

Rubber Length (X):

39 in 991 mm

Shed spacing (S):

1.95 in 50 mm

Shed Projection (P):

1.86 in 47 mm

Dry Arc Distance:

41.2 in 1,046 mm

Leakage Distance:

106.1 in 2,696 mm

Electricals Values

60 Hz dry Flashover (Min. Withstand):

395 kV 371 kV

60 Hz Wet Flashover (Min. Withstand):

366 kV 287 kV

CIFO Positive (Min. Withstand):

680 kV 608 kV

CIFO Negative (Min. Withstand):

759 kV 646 kV

Mechanical Values

Max. Design Cant. Load (MDCL):

1,871 lbs 8.3 kN

Specified Cant. Load (SCL):

3,742 lbs 16.6 kN

Specified Tensile Load (STL):

15,000 lbs 66.7 kN

This drawing contains confidential information that is the property of MacLean Power, L.L.C. ("MacLean"). Use of MacLean's confidential information without MacLean's express written consent is strictly prohibited and may expose you to legal liability. If you believe that you received this material in error, please destroy it or return it to "MacLean Power, L.L.C., 7801 Park Place Rd., York, South Carolina 29745, USA."

Notes:

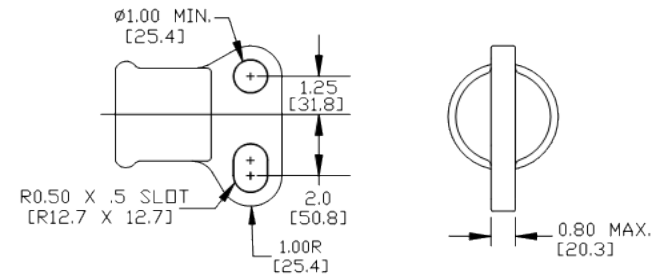
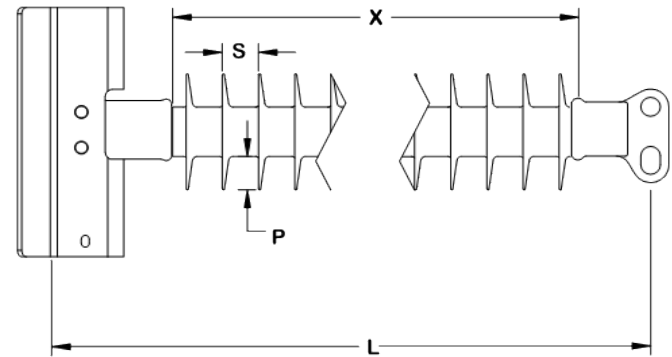
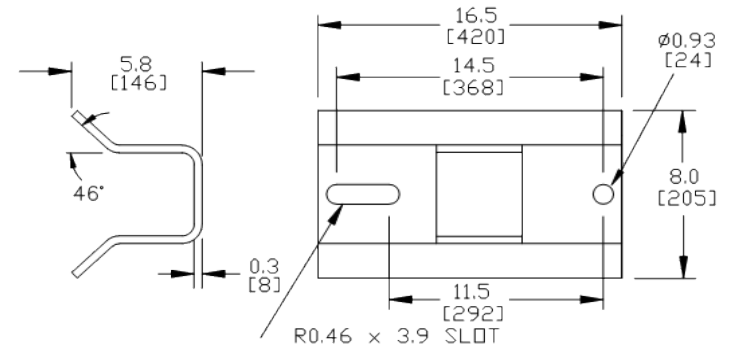

Dimension: inches [millimeters]

NOTE: Drawing not actual depiction of insulator appearance.

Silicone rubber sheath and sheds complies with applicable ANSI and IEC standards.

Prepared By: Stephen Lucci

MPS Catalog Number

S1 40 80 037 MX AL 023

Date: 03/23/2022

End Fittings

Tower End Fitting:

Y-Clevis / Forged Steel

Line End Fitting:

Ball / Forged Steel
/ (ANSI 52-5)

Material

Corona Ring (Line):

None

Corona Rings are recommended for applications of 230 kV and above

Number of Sheds:

11 large 12 standard

Rod Diameter:

16 mm

Weight Estimate:

9 lbs 4 kg

Dimensional Values

Section Length (L):

48.2 in 1,224 mm

Rubber Length (X):

37 in 940 mm

Standard Shed Height (P1):

1.5 in 38 mm

Large Shed Height (P2):

2 in 51 mm

Projection Ration (S/P):

- 1.5

Shed Spacing (S):

3 in 76 mm

Dry Arc Distance:

38.8 in 986 mm

Leakage Distance:

103.5 in 2,629 mm

Electricals Values

60 Hz dry Flashover (Min. Withstand):

384 kV 356 kV

60 Hz Wet Flashover (Min. Withstand):

346 kV 301 kV

CIFO Positive (Min. Withstand):

662 kV 572 kV

CIFO Negative (Min. Withstand):

705 kV 617 kV

Mechanical Values

Specified Mech. Load (SML):

25,000 lbs 111.2 kN

Routine Test Load (RTL):

12,500 lbs 55.6 kN

Notes:

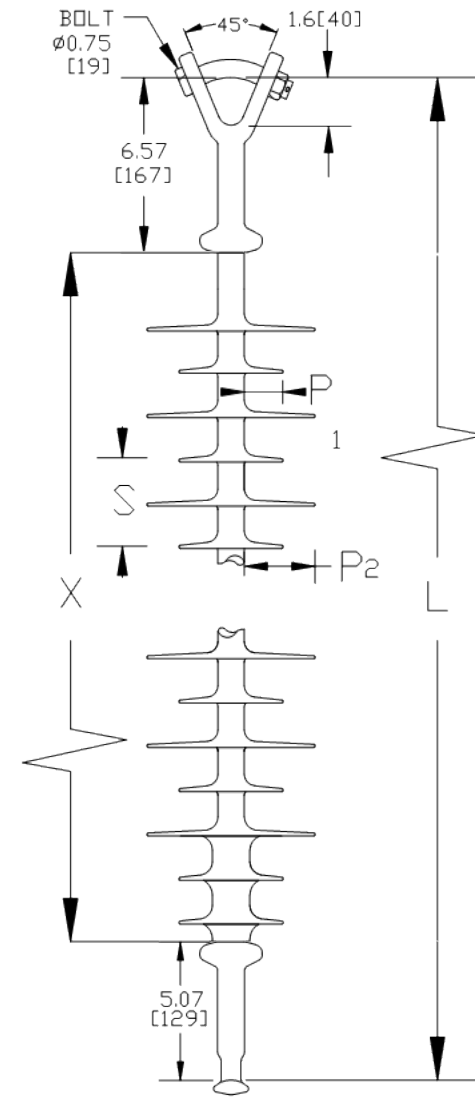

Dimension: inches [millimeters]

NOTE: Drawing not actual depiction of insulator appearance.

Silicone rubber sheath and sheds complies with applicable ANSI and IEC standards.

Prepared By: Stephen Lucci



MacLean Power Systems

B2911050T12067MX Ultimate Combined Load Curve

Factor of Safety = 1

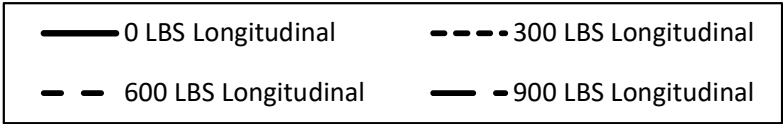

Assumptions:
-Loading sequence is Longitudinal, Vertical, Transverse
-Factor of Safety applied to entire system
-Negligible downward tip deflection
-Static moduli values
-Confidence level of 95%

