

## Braced Post Insulator Assembly B2911054T12059MX

1) H2 91 10 043 MX SS 022	[1]
2) S1 40 80 042 MX AL 027	[1]
3) Socket/Y-Clevis (SYC-56)	[1]
4) Turnbuckle (G-227-NBC-3/4x6C)	[1]
5) Shackle (ASH-55-BC)	[1]

### ASSEMBLY DIMENSIONAL VALUES

Post Section Length (PSL)	54.0 in	1,372 mm
Suspension Section Length (SSL)	54.0 in	1,372 mm
Height of Assembly (H)	59.0 in	1,499 mm
Length of Brace (B)	77.7 in	1,974 mm
Upper Pole Connection Offset (A)*	2.0 in	51 mm
Angle Between Insulators (C)		48 Degrees
Dry Arc Distance	43.0 in	1,092 mm
Leakage Distance	116.7 in	2,964 mm

\*This connection bracket to be supplied by customer

### ASSEMBLY ELECTRICAL VALUES\*

60 Hz Dry F.O. (Min. Withstand)	411 kV	(386) kV
60 Hz Wet F.O. (Min. Withstand)	381 kV	(299) kV
CIFO+ (Min. Withstand)	709 kV	(633) kV
CIFO- (Min. Withstand)	783 kV	(672) kV

\*Values shown are based on minimum electricals for the assembly

### ASSEMBLY MECHANICAL VALUES

Maximum Working Vertical Load	9,289 lbs	41.3 kN
-------------------------------	-----------	---------

This drawing contains confidential information that is the property of MacLean Power, L.L.C. ("MacLean"). Use of MacLean's confidential information without MacLean's express written consent is strictly prohibited and may expose you to legal liability. If you believe that you received this material in error, please destroy it or return it to "MacLean Power, L.L.C., 7801 Park Place Rd., York, South Carolina 29745, USA."

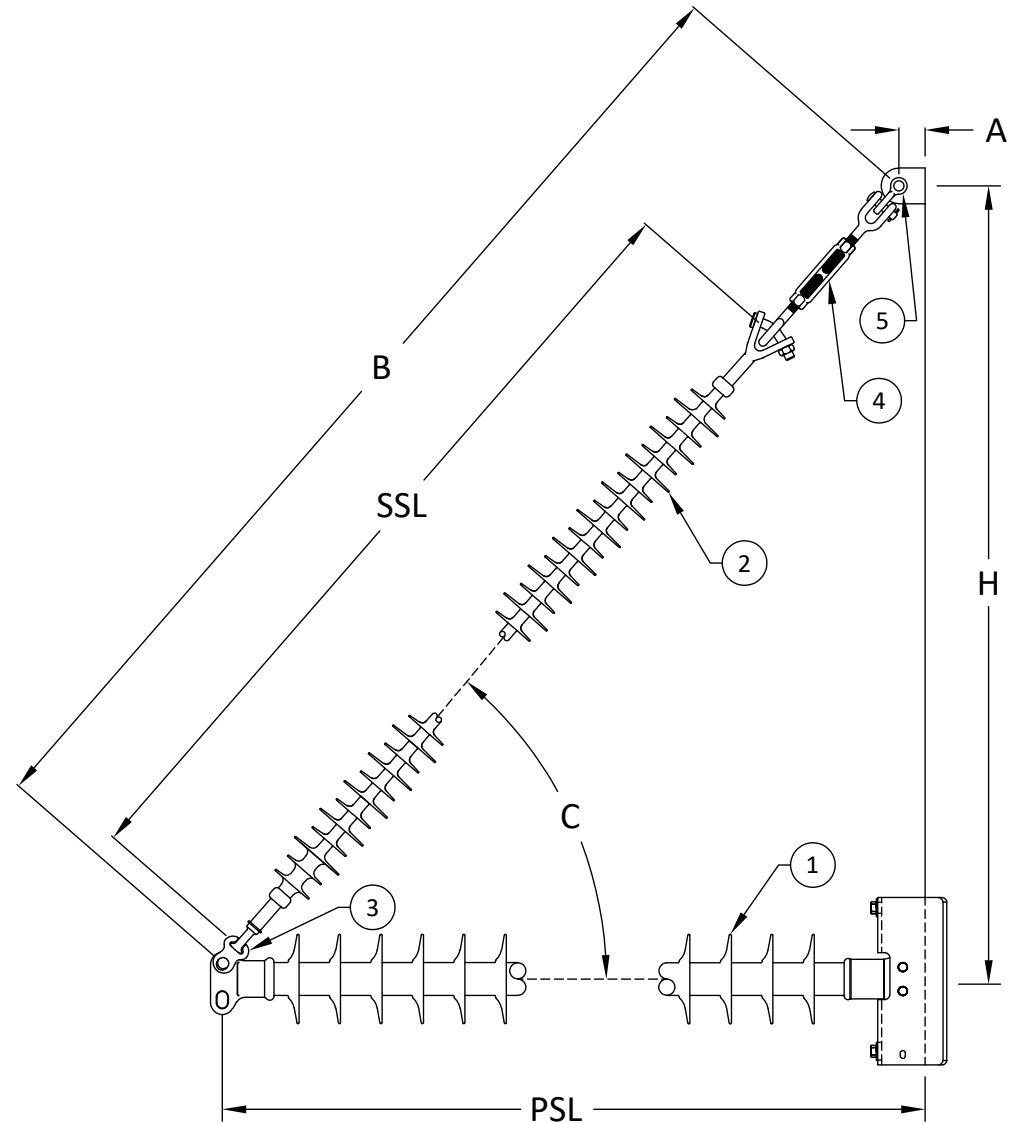

MPS Catalog Number

**H2 91 10 043 MX SS 022**

Date: 04/13/2022

**End Fittings**

Tower End Fitting:

Gain / 0 deg / Steel

Line End Fitting:

2 HL Drop Tongue / Galv. Ductile Iron

**Material**

Corona Ring (Line):

None

Corona Rings are recommended for applications of 230 kV and above

Mounting Angle:

0 deg

Number of Sheds:

22

Rod Diameter:

2.5 in

Weight Estimate:

58 lbs

26 kg

**Dimensional Values**

Section Length (L):

54 in 1,372 mm

Rubber Length (X):

43 in 1,092 mm

Shed spacing (S):

1.95 in 50 mm

Shed Projection (P):

1.86 in 47 mm

Dry Arc Distance:

45.1 in 1,145 mm

Leakage Distance:

116.7 in 2,965 mm

**Electricals Values**

60 Hz dry Flashover (Min. Withstand):

429 kV 403 kV

60 Hz Wet Flashover (Min. Withstand):

398 kV 313 kV

CIFO Positive (Min. Withstand):

742 kV 662 kV

CIFO Negative (Min. Withstand):

809 kV 701 kV

**Mechanical Values**

Max. Design Cant. Load (MDCL):

1,706 lbs 7.6 kN

Specified Cant. Load (SCL):

3,412 lbs 15.2 kN

Specified Tensile Load (STL):

15,000 lbs 66.7 kN

This drawing contains confidential information that is the property of MacLean Power, L.L.C. ("MacLean"). Use of MacLean's confidential information without MacLean's express written consent is strictly prohibited and may expose you to legal liability. If you believe that you received this material in error, please destroy it or return it to "MacLean Power, L.L.C., 7801 Park Place Rd., York, South Carolina 29745, USA."

Notes:

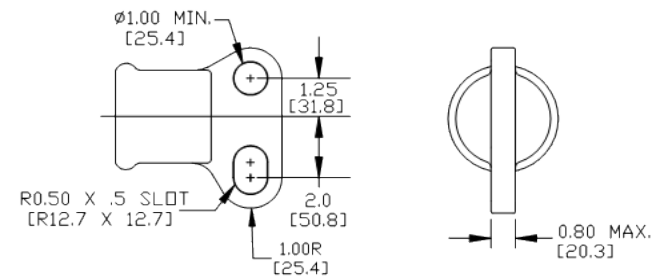
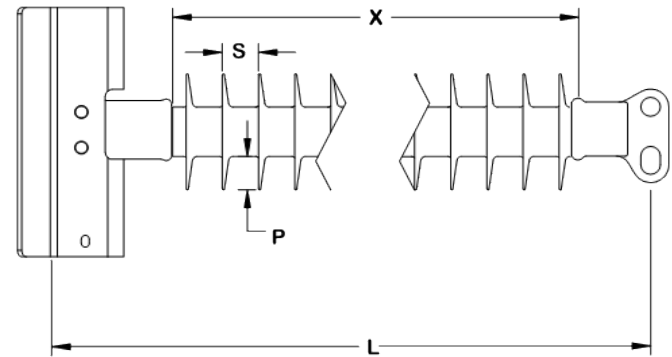
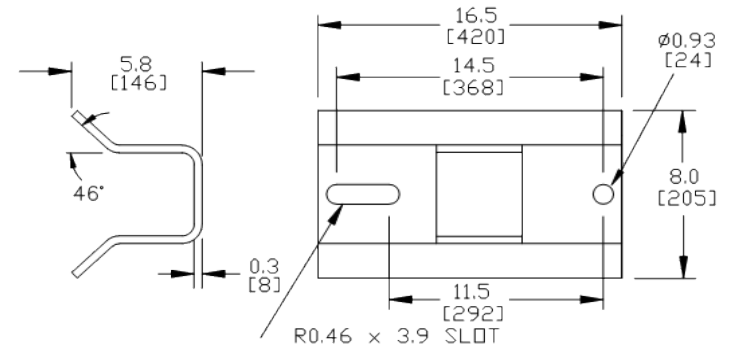

Dimension: inches [millimeters]

NOTE: Drawing not actual depiction of insulator appearance.

Silicone rubber sheath and sheds complies with applicable ANSI and IEC standards.

Prepared By: Stephen Lucci

MPS Catalog Number

**S1 40 80 042 MX AL 027**

Date: 03/24/2022

**End Fittings**

Tower End Fitting:

Y-Clevis / Forged Steel

Line End Fitting:

Ball / Forged Steel  
/ (ANSI 52-5)

**Material**

Corona Ring (Line):

None

Corona Rings are recommended for applications of 230 kV and above

Number of Sheds:

13 large      14 standard

Rod Diameter:

16 mm

Weight Estimate:

9.9 lbs      5 kg

**Dimensional Values**

Section Length (L):

54 in      1,372 mm

Rubber Length (X):

42 in      1,067 mm

Standard Shed Height (P1):

1.5 in      38 mm

Large Shed Height (P2):

2 in      51 mm

Projection Ration (S/P):

-      1.5

Shed Spacing (S):

3 in      76 mm

Dry Arc Distance:

44.8 in      1,138 mm

Leakage Distance:

121.8 in      3,094 mm

**Electricals Values**

60 Hz dry Flashover (Min. Withstand):

441 kV      408 kV

60 Hz Wet Flashover (Min. Withstand):

395 kV      344 kV

CIFO Positive (Min. Withstand):

757 kV      656 kV

CIFO Negative (Min. Withstand):

803 kV      704 kV

**Mechanical Values**

Specified Mech. Load (SML):

25,000 lbs      111.2 kN

Routine Test Load (RTL):

12,500 lbs      55.6 kN

Notes:

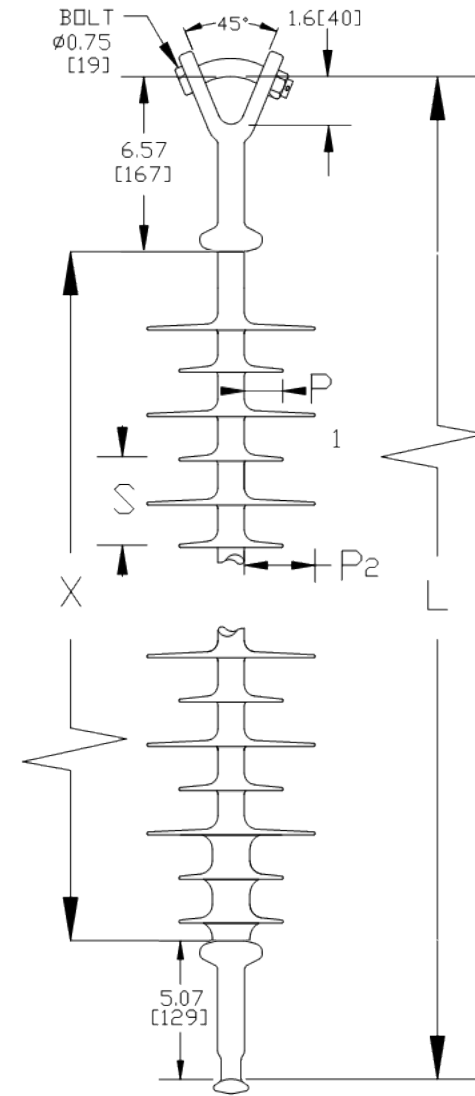

Dimension: inches [millimeters]

NOTE: Drawing not actual depiction of insulator appearance.

Silicone rubber sheath and sheds complies with applicable ANSI and IEC standards.

Prepared By: Stephen Lucci



MacLean Power Systems

## B2911053T12059AA Ultimate Combined Load Curve

Factor of Safety = 1

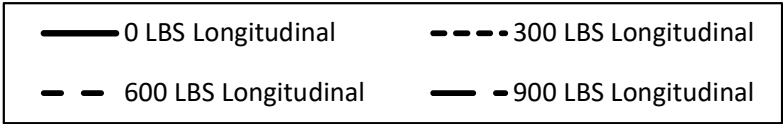

**Assumptions:**  
-Loading sequence is Longitudinal, Vertical, Transverse  
-Factor of Safety applied to entire system  
-Negligible downward tip deflection  
-Static moduli values  
-Confidence level of 95%

