

Braced Post Insulator Assembly B2911061T12074MX

1) H2 91 10 050 MX SS 026	[1]
2) S1 40 80 048 MX AL 031	[1]
3) Socket/Y-Clevis (SYC-56)	[1]
4) Turnbuckle (G-227-NBC-3/4x12C)	[1]
5) Shackle (ASH-55-BC)	[1]

ASSEMBLY DIMENSIONAL VALUES

Post Section Length (PSL)	61.0 in	1,549 mm
Suspension Section Length (SSL)	60.0 in	1,524 mm
Height of Assembly (H)	74.0 in	1,880 mm
Length of Brace (B)	93.7 in	2,380 mm
Upper Pole Connection Offset (A)*	2.0 in	51 mm
Angle Between Insulators (C)		51 Degrees
Dry Arc Distance	50.3 in	1,278 mm
Leakage Distance	137.9 in	3,503 mm

*This connection bracket to be supplied by customer

ASSEMBLY ELECTRICAL VALUES*

60 Hz Dry F.O. (Min. Withstand)	476 kV	(446) kV
60 Hz Wet F.O. (Min. Withstand)	440 kV	(348) kV
CIFO+ (Min. Withstand)	825 kV	(734) kV
CIFO- (Min. Withstand)	874 kV	(775) kV

*Values shown are based on minimum electricals for the assembly

ASSEMBLY MECHANICAL VALUES

Maximum Working Vertical Load	9,714 lbs	43.2 kN
-------------------------------	-----------	---------

This drawing contains confidential information that is the property of MacLean Power, L.L.C. ("MacLean"). Use of MacLean's confidential information without MacLean's express written consent is strictly prohibited and may expose you to legal liability. If you believe that you received this material in error, please destroy it or return it to "MacLean Power, L.L.C., 7801 Park Place Rd., York, South Carolina 29745, USA."

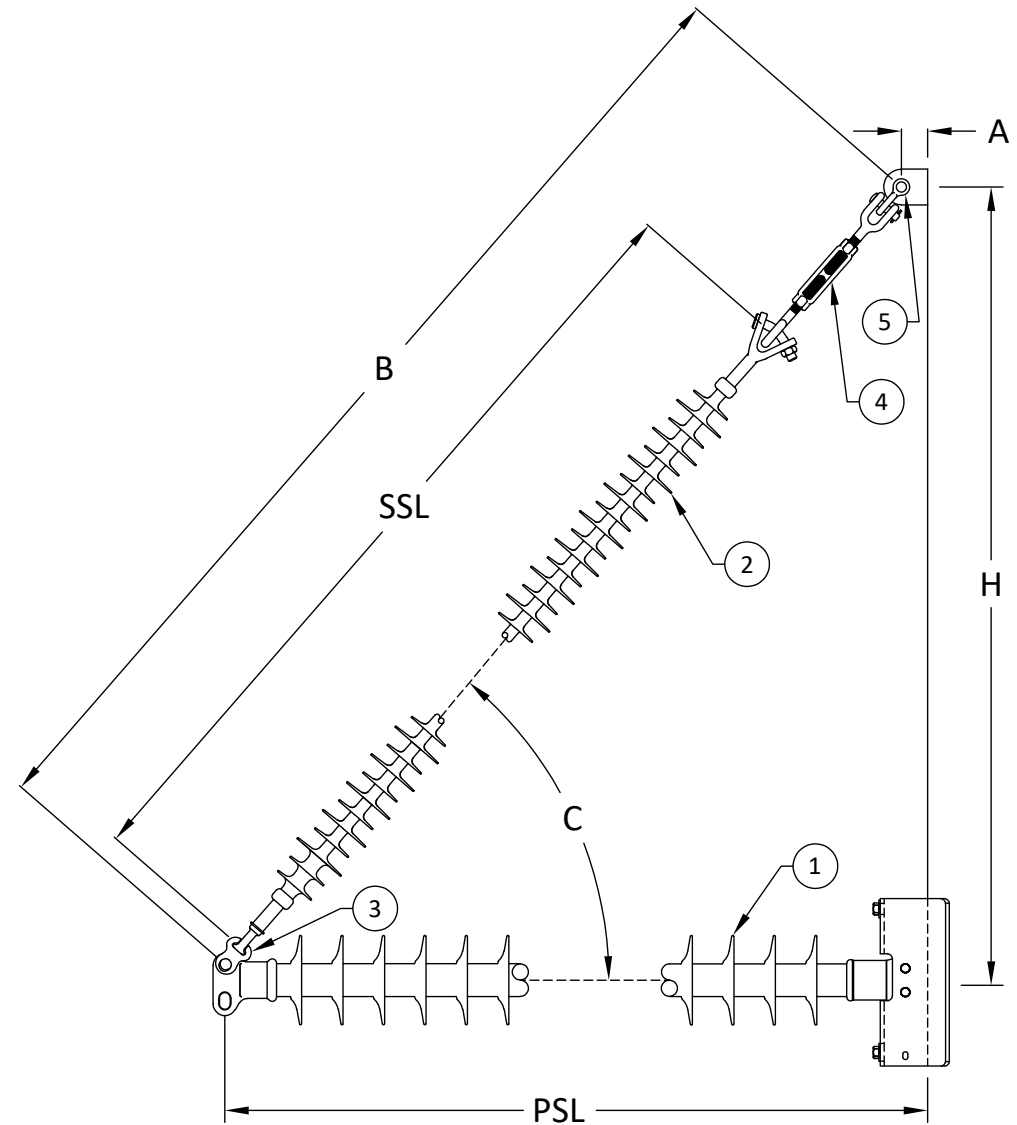

MPS Catalog Number

H2 91 10 050 MX SS 026

Date: 04/13/2022

End Fittings

Tower End Fitting:

Gain / 0 deg / Steel

Line End Fitting:

2 HL Drop Tongue / Galv. Ductile Iron

Material

Corona Ring (Line):

None

Corona Rings are recommended for applications of 230 kV and above

Mounting Angle:

0 deg

Number of Sheds:

26

Rod Diameter:

2.5 in

Weight Estimate:

62.5 lbs

28 kg

Dimensional Values

Section Length (L):

61 in 1,549 mm

Rubber Length (X):

50 in 1,270 mm

Shed spacing (S):

1.95 in 50 mm

Shed Projection (P):

1.86 in 47 mm

Dry Arc Distance:

52.9 in 1,343 mm

Leakage Distance:

137.9 in 3,503 mm

Electricals Values

60 Hz dry Flashover (Min. Withstand):

498 kV 468 kV

60 Hz Wet Flashover (Min. Withstand):

461 kV 365 kV

CIFO Positive (Min. Withstand):

866 kV 769 kV

CIFO Negative (Min. Withstand):

912 kV 811 kV

Mechanical Values

Max. Design Cant. Load (MDCL):

1,494 lbs 6.6 kN

Specified Cant. Load (SCL):

2,988 lbs 13.3 kN

Specified Tensile Load (STL):

15,000 lbs 66.7 kN

This drawing contains confidential information that is the property of MacLean Power, L.L.C. ("MacLean"). Use of MacLean's confidential information without MacLean's express written consent is strictly prohibited and may expose you to legal liability. If you believe that you received this material in error, please destroy it or return it to "MacLean Power, L.L.C., 7801 Park Place Rd., York, South Carolina 29745, USA."

Notes:

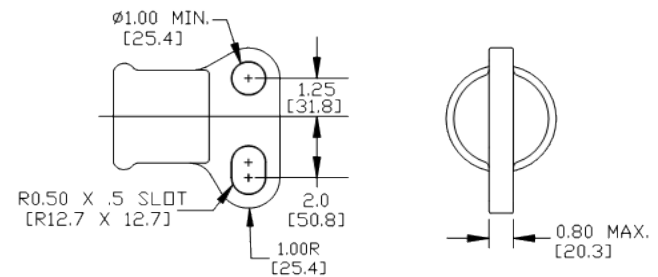
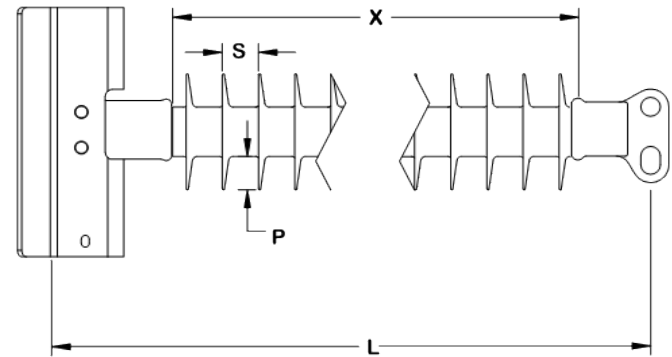
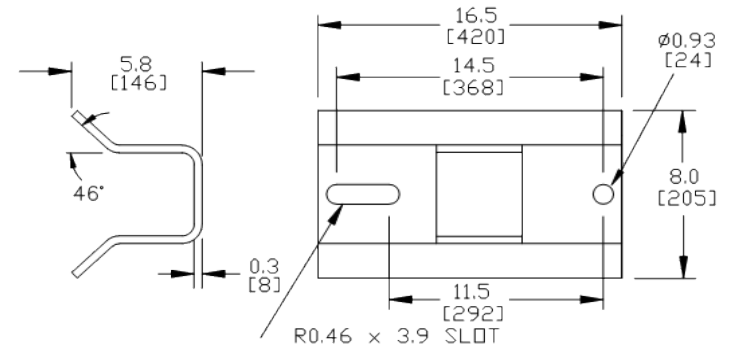

Dimension: inches [millimeters]

NOTE: Drawing not actual depiction of insulator appearance.

Silicone rubber sheath and sheds complies with applicable ANSI and IEC standards.

Prepared By: Stephen Lucci

MPS Catalog Number

S1 40 80 048 MX AL 031

Date: 03/25/2022

End Fittings

Tower End Fitting:

Y-Clevis / Forged Steel

Line End Fitting:

Ball / Forged Steel
/ (ANSI 52-5)

Material

Corona Ring (Line):

None

Corona Rings are recommended for applications of 230 kV and above

Number of Sheds:

15 large 16 standard

Rod Diameter:

16 mm

Weight Estimate:

10.7 lbs 5 kg

Dimensional Values

Section Length (L):

60 in 1,524 mm

Rubber Length (X):

48 in 1,219 mm

Standard Shed Height (P1):

1.5 in 38 mm

Large Shed Height (P2):

2 in 51 mm

Projection Ration (S/P):

- 1.5

Shed Spacing (S):

3 in 76 mm

Dry Arc Distance:

50.7 in 1,288 mm

Leakage Distance:

140.1 in 3,559 mm

Electricals Values

60 Hz dry Flashover (Min. Withstand):

497 kV 459 kV

60 Hz Wet Flashover (Min. Withstand):

443 kV 386 kV

CIFO Positive (Min. Withstand):

849 kV 739 kV

CIFO Negative (Min. Withstand):

898 kV 789 kV

Mechanical Values

Specified Mech. Load (SML):

25,000 lbs 111.2 kN

Routine Test Load (RTL):

12,500 lbs 55.6 kN

Notes:

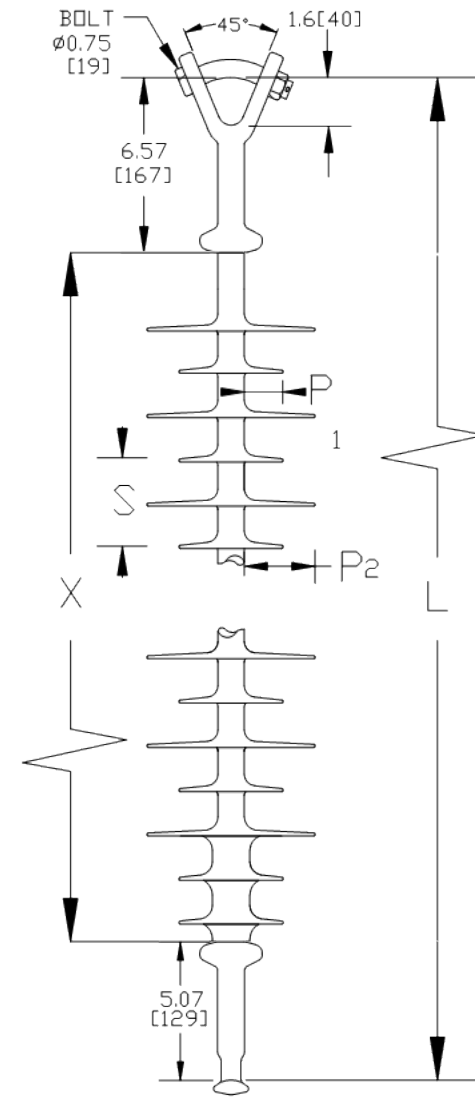

Dimension: inches [millimeters]

NOTE: Drawing not actual depiction of insulator appearance.

Silicone rubber sheath and sheds complies with applicable ANSI and IEC standards.

Prepared By: Stephen Lucci



MacLean Power Systems

B2911061T12061MX Ultimate Combined Load Curve

Factor of Safety = 1

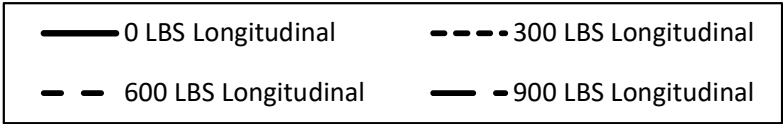

Assumptions:
-Loading sequence is Longitudinal, Vertical, Transverse
-Factor of Safety applied to entire system
-Negligible downward tip deflection
-Static moduli values
-Confidence level of 95%

