

Braced Post Insulator Assembly B2911069T12061AA

1) H2 91 10 058 AX SS 022	[1]
2) S1 40 80 054 MA AL 035	[1]
3) Socket/Y-Clevis (SYC-56)	[1]
4) Turnbuckle (G-227-NBC-3/4x6C)	[1]
5) Shackle (ASH-55-BC)	[1]

ASSEMBLY DIMENSIONAL VALUES

Post Section Length (PSL)	69.1 in	1,755 mm
Suspension Section Length (SSL)	66.0 in	1,676 mm
Height of Assembly (H)	61.0 in	1,549 mm
Length of Brace (B)	89.9 in	2,283 mm
Upper Pole Connection Offset (A)*	2.0 in	51 mm
Angle Between Insulators (C)		41 Degrees
Dry Arc Distance	54.1 in	1,374 mm
Leakage Distance	157.0 in	3,988 mm

*This connection bracket to be supplied by customer

ASSEMBLY ELECTRICAL VALUES*

60 Hz Dry F.O. (Min. Withstand)	509 kV	(478) kV
60 Hz Wet F.O. (Min. Withstand)	470 kV	(374) kV
CIFO+ (Min. Withstand)	885 kV	(786) kV
CIFO- (Min. Withstand)	931 kV	(828) kV

*Values shown are based on minimum electricals for the assembly

ASSEMBLY MECHANICAL VALUES

Maximum Working Vertical Load	8,312 lbs	37.0 kN
-------------------------------	-----------	---------

This drawing contains confidential information that is the property of MacLean Power, L.L.C. ("MacLean"). Use of MacLean's confidential information without MacLean's express written consent is strictly prohibited and may expose you to legal liability. If you believe that you received this material in error, please destroy it or return it to "MacLean Power, L.L.C., 7801 Park Place Rd., York, South Carolina 29745, USA."

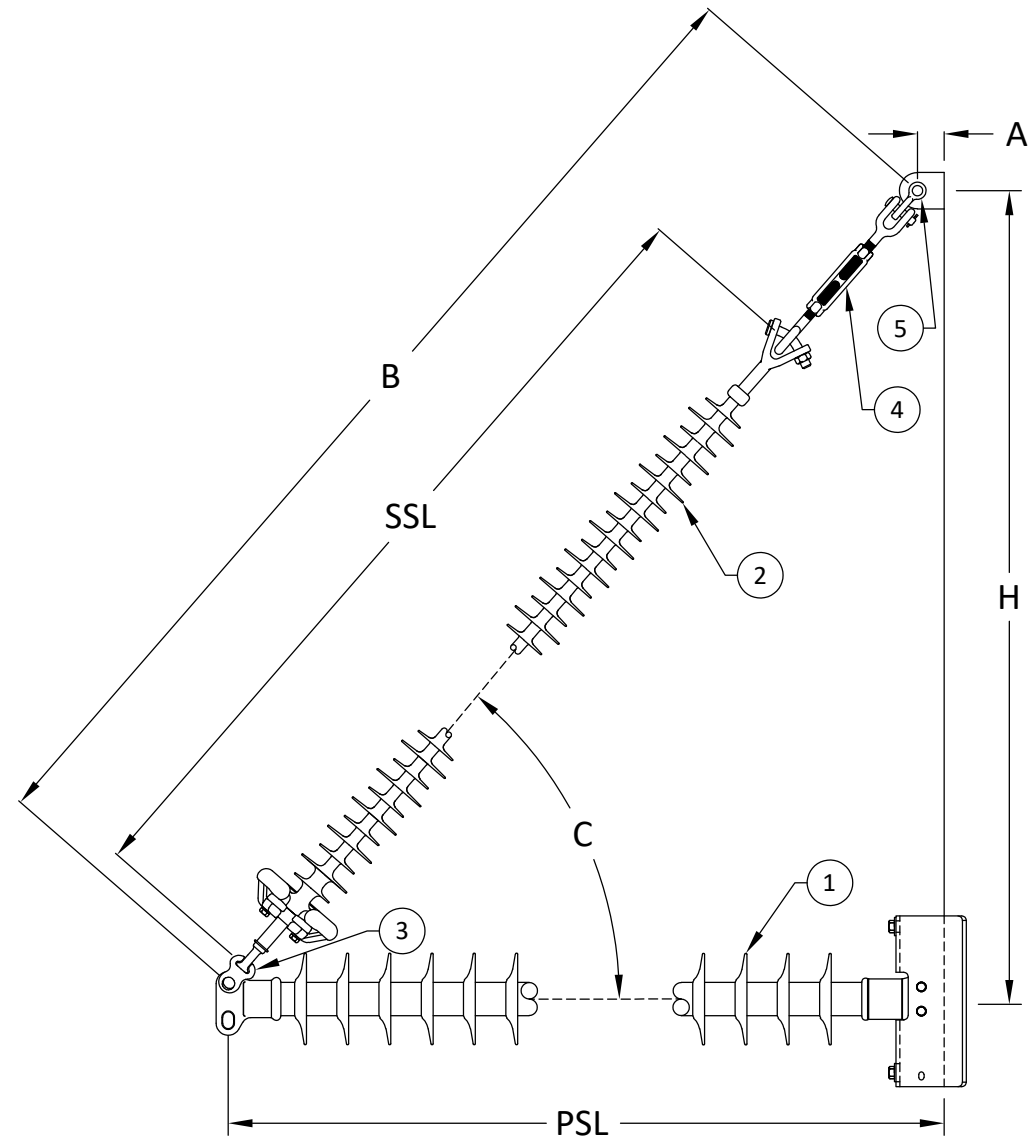

MPS Catalog Number:

Date:

H2 91 10 058 AX SS 022

04/20/2022

End Fittings

Tower End Fitting:

Gain / 0 deg / Steel

Line End Fitting:

Anchor / Ductile Iron
2 HL Drop Tongue / Galv. Ductile Iron

Material

Corona Ring (Tower):

None

Corona Ring (Line):

None

Corona Rings are recommended for applications of 230 kV and above

Mounting Angle:

0 deg

Number of Sheds:

22

Rod Diameter:

2.5 in

Weight Estimate:

78.7 lbs

36 kg

Dimensional Values

Section Length (L):

69.1 in 1,755 mm

Rubber Length (X):

58 in 1,473 mm

Shed spacing (S):

2.5 in 64 mm

Shed Projection (P):

2.4 in 61 mm

Dry Arc Distance:

60.9 in 1,547 mm

Leakage Distance:

157 in 3,988 mm

Electricals Values

60 Hz dry Flashover (Min. Withstand):

568 kV 533 kV

60 Hz Wet Flashover (Min. Withstand):

523 kV 418 kV

CIFO Positive (Min. Withstand):

992 kV 878 kV

CIFO Negative (Min. Withstand):

1032 kV 923 kV

Mechanical Values

Max. Design Cant. Load (MDCL):

1,287 lbs 5.7 kN

Specified Cant. Load (SCL):

2,574 lbs 11.4 kN

Specified Tensile Load (STL):

15,000 lbs 66.7 kN

This drawing contains confidential information that is the property of MacLean Power, L.L.C. ("MacLean"). Use of MacLean's confidential information without MacLean's express written consent is strictly prohibited and may expose you to legal liability. If you believe that you received this material in error, please destroy it or return it to "MacLean Power, L.L.C., 7801 Park Place Rd., York, South Carolina 29745, USA."

Notes:

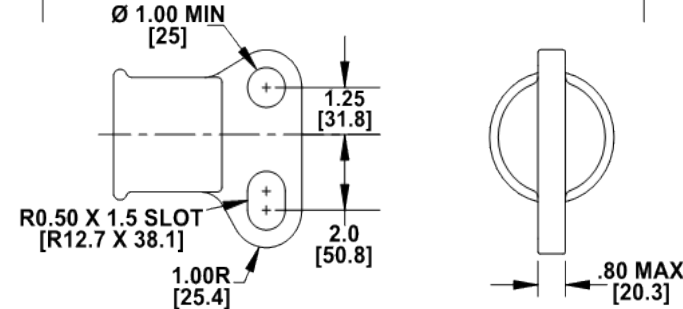
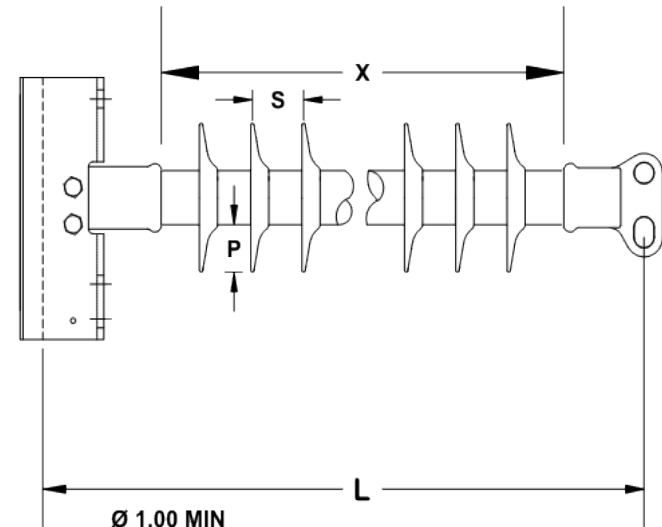
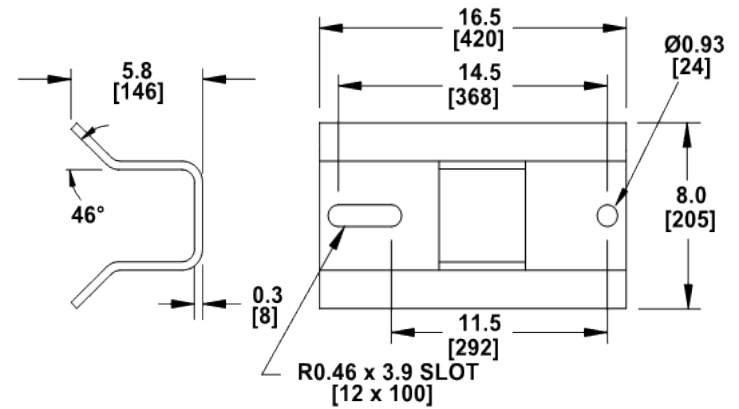

Dimension: inches [millimeters]

NOTE: Drawing not actual depiction of insulator appearance.

Silicone rubber sheath and sheds complies with applicable ANSI and IEC standards.

Prepared By: Stephen Lucci

MPS Catalog Number

S1 40 80 054 MA AL 035

Date: 04/11/2022

End Fittings

Tower End Fitting:

Y-Clevis / Forged Steel

Line End Fitting:

Ball / Forged Steel
 / (ANSI 52-5)

Material

Corona Ring (Line):

8" Corona Ring

Corona Rings are recommended for applications of 230 kV and above

Number of Sheds:

17 large 18 standard

Rod Diameter:

16 mm

Weight Estimate:

13.8 lbs 6 kg

Dimensional Values

Section Length (L):

66 in 1,676 mm

Rubber Length (X):

54 in 1,372 mm

Standard Shed Height (P1):

1.5 in 38 mm

Large Shed Height (P2):

2 in 51 mm

Projection Ration (S/P):

- 1.5

Shed Spacing (S):

3 in 76 mm

Dry Arc Distance:

54.1 in 1,374 mm

Leakage Distance:

158.4 in 4,023 mm

Electricals Values

60 Hz dry Flashover (Min. Withstand):

529 kV 488 kV

60 Hz Wet Flashover (Min. Withstand):

470 kV 409 kV

CIFO Positive (Min. Withstand):

902 kV 787 kV

CIFO Negative (Min. Withstand):

953 kV 838 kV

Mechanical Values

Specified Mech. Load (SML):

25,000 lbs 111.2 kN

Routine Test Load (RTL):

12,500 lbs 55.6 kN

Notes:

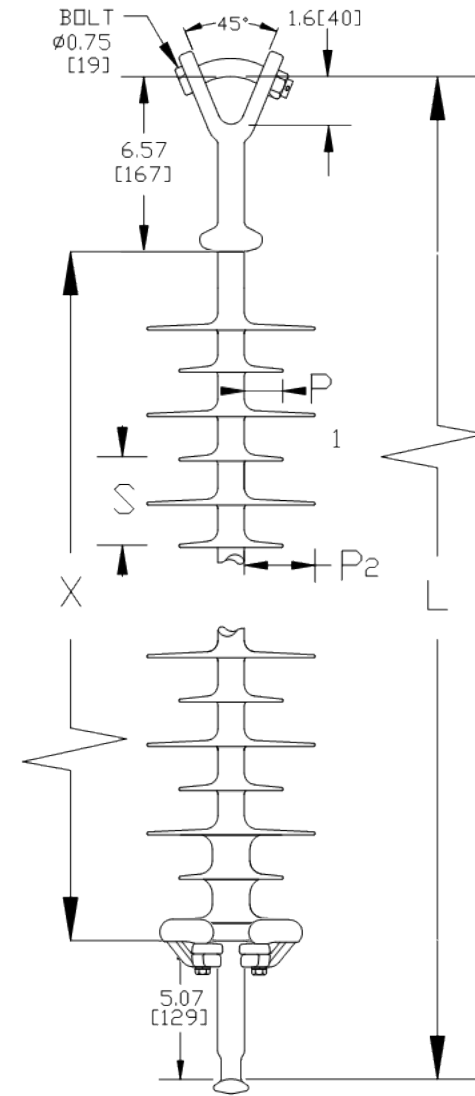

Dimension: inches [millimeters]

NOTE: Drawing not actual depiction of insulator appearance.

Silicone rubber sheath and sheds complies with applicable ANSI and IEC standards.

Prepared By: Stephen Lucci



MacLean Power Systems

B2911069T12061AA Ultimate Combined Load Curve

Factor of Safety = 1



Assumptions:
-Loading sequence is Longitudinal, Vertical, Transverse
-Factor of Safety applied to entire system
-Negligible downward tip deflection
-Static moduli values
-Confidence level of 95%

