

REVISIONS				
NO.	DATE	DESCRIPTION	BY	CKD

ASSEMBLE CLEVIS EYE TO CLAMP BODY FOR ASO-684-1-C

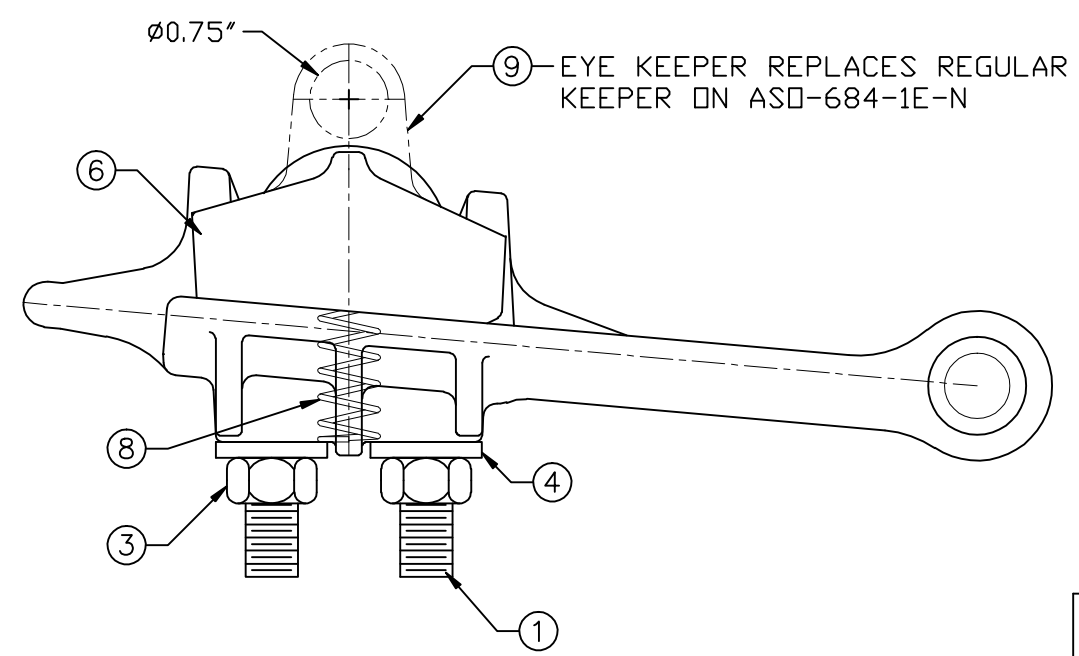
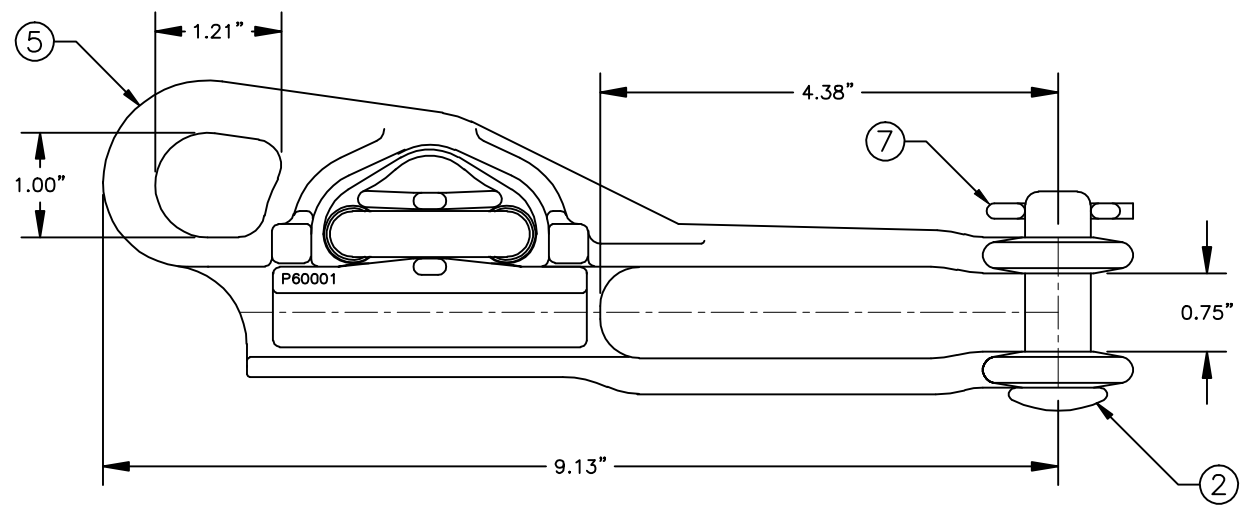
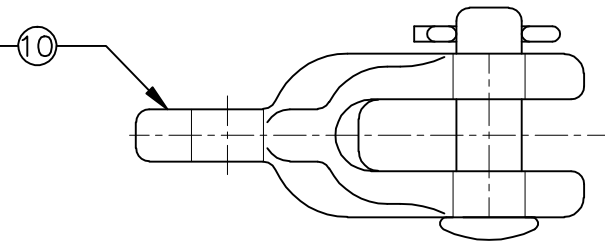

ITEM NO.	PART NO.	CAT. NO.	DESCRIPTION	QUANTITY			
				A	B	C	D
1	P56020	H-0201-23	1/2" U-BOLT	1	1	1	
2	P56093	H-0315-02	5/8" x 1-7/8" CLEVIS PIN	1	1	1	
3	P56138	H-0400-04-W	1/2"-13 HEX NUT FIN	2	2	2	
4	P56294	H-0500-04	1/2" FLATWASHER	2	2	2	
5	P60000	*ASO-684-1B	ASO-684-1 BODY (NEW)	1	1	1	
6	P60001	*ASO-684-1K	ASO-684-1 KEEPER (NEW)	1	1		
7	P61134	M-111-3	LONG COTTER PIN 5	1	1	1	
8	P61190	H-0476-03	0.312" x 2.38" COMP. SPRING	1	1	1	
9	P60001E	*ASO-684-1EK	ASO-684-1 EYE KEEPER			1	
10	F327212	SCE-55-500	CLEVIS EYE		1		

ASSEMBLY NUMBER	REF. NO.
ASO-684-1-N	A
ASO-684-1-C	B
ASO-684-1E-N	C
-----	D

- NOTES:
- MATERIAL - BODY AND KEEPER: A356-T6 ALUMINUM ALLOY

HARDWARE: STEEL, HOT DIP GALVANIZED PER ASTM-A153

COTTER PIN AND COMP. SPRING: STAINLESS STEEL
 - ULTIMATE STRENGTH - BODY: 8,000 LBS.
EYE: 8,000 LBS.
 - CLAMPING RANGE - 0.25" TO 0.684"

MACLEAN POWER SYSTEMS
A Maclean-fogg Company

HOT LINE DEAD END CLAMP
ASO-684-1-N, ASO-684-1-C,
ASO-684-1E-N

This information is confidential and is the property of Maclean Power Systems. It may not be made public or reproduced except that the Customer may make copies for use solely in installation, maintenance, and operation of products supplied by Maclean Power Systems.

ENG. REF.

DATE: 12/07/2011	SCALE: NONE	NO. BC8516-1	R / 0	SH. 1 / OF 1
DWN. BY: CDR	CKD. BY:	APR. BY:		