

REVISIONS				
NO.	DATE	DESCRIPTION	BY	CKD

ITEM NO.	PART NO.	CAT. NO.	DESCRIPTION	QUANTITY			
				A	B	C	D
1	P56138	H-0400-04-W	1/2"-13 HEX NUT FIN	4	4	4	
2	P56230	H-0470-06	0.5" x 2.75" SPRING	1	1	1	
3	P56294	H-0500-04	1/2" FLATWASHER	4	4	4	
4	P61134	M-111-3	LONG COTTER PIN	1	1	1	
5	P61165	H-0315-04	5/8" x 2-9/16" CLEVIS PIN	1	1	1	
6	P62164	*HDSO-116-B	HDSO-116 BODY	1	1	1	
7	P62166	*HDSO-116-K	HDSO-116 KEEPER	1	-	1	
8	P62681	H-0201-32	1/2" STEEL U-BOLT	2	2	2	
9	P62165	HDSO-116-EK	HDSO-116 EYE KEEPER	-	1	-	
10	P56399	H-0520-04	1/2" LOCKWASHER	-	-	4	

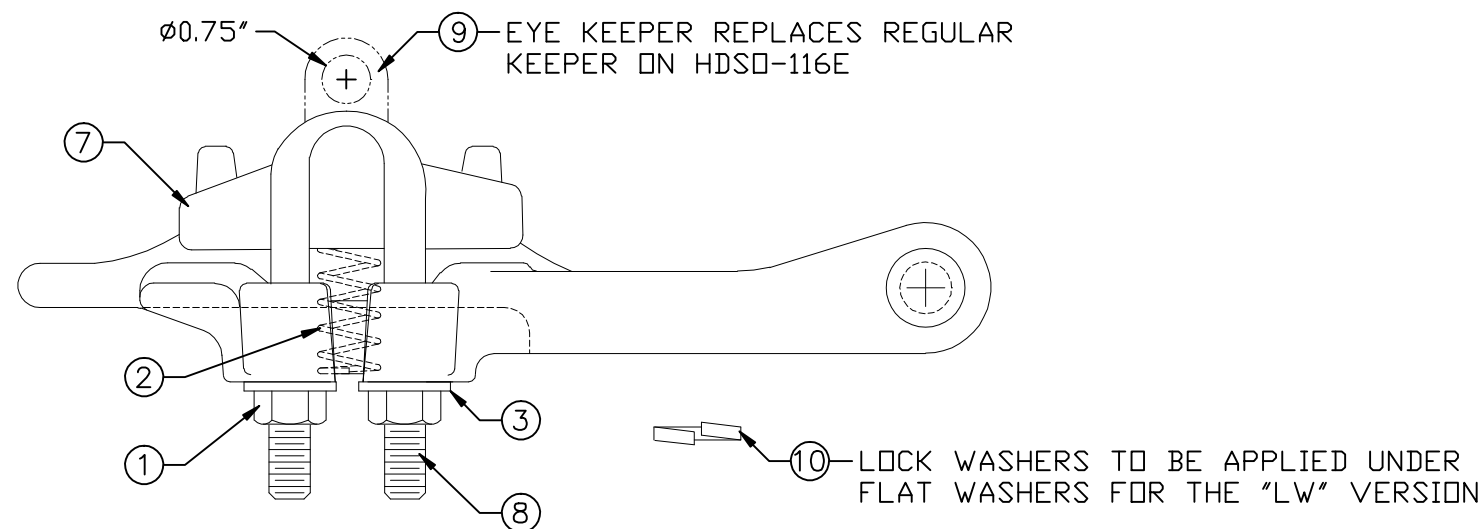
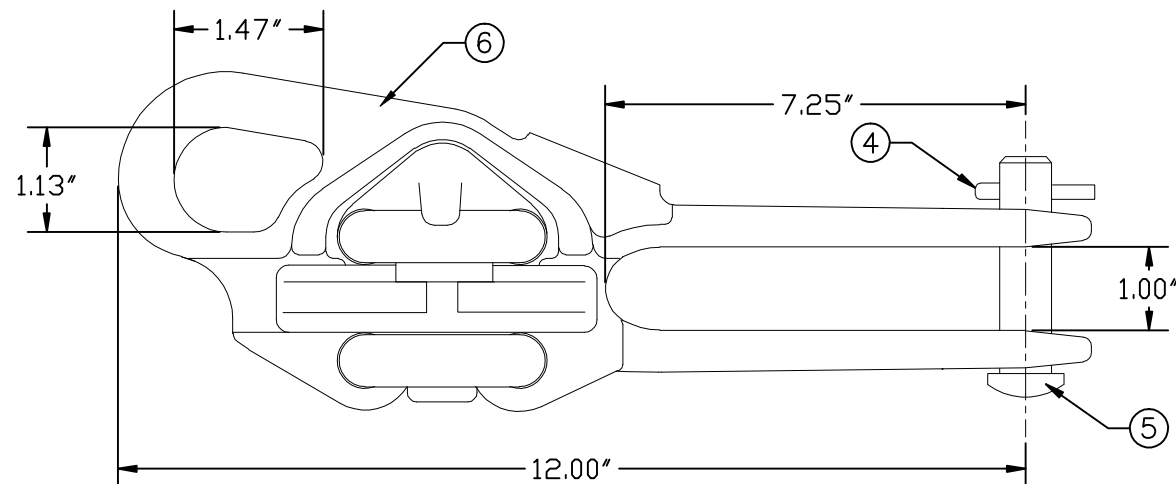

ASSEMBLY NUMBER	REF. NO.
HDSO-116	A
HDSO-116E	B
HDSO-116-LW	C
	D

NOTES:

1. MATERIAL - BODY AND KEEPER:  
A356-T6 ALUMINUM ALLOY

HARDWARE:  
STEEL, HOT DIP GALVANIZED PER  
ASTM-A153

COTTER PIN AND COMP. SPRING:  
STAINLESS STEEL

2. ULTIMATE STRENGTH - BODY: 12,000 LBS.  
EYE: 8,000 LBS.

3. CLAMPING RANGE - 0.68" TO 1.16"



**MACLEAN POWER SYSTEMS**  
A Maclean-fogg Company

HOT LINE DEAD END CLAMP  
HDSO-116, HDSO-116E, HDSO-116-LW

This information is confidential and is the property of Maclean Power Systems. It may not be made public or reproduced except that the Customer may make copies for use solely in installation, maintenance, and operation of products supplied by Maclean Power Systems.

DATE: 12/08/2011	SCALE: NONE	NO.	BC8521-1	R / 0	SH. 1 / OF 1
DWN. BY: CDR	CKD. BY:	APR. BY:			

ENG. REF.