

REVISIONS				
NO.	DATE	DESCRIPTION	BY	CKD

ITEM NO.	PART NO.	CAT. NO.	DESCRIPTION	QUANTITY			
				A	B	C	D
1	P61165	H-0315-04	5/8"Ø x 2-9/16" CLEVIS PIN	1			
2	P56138	H-0400-04-W	1/2"-13 HEX NUT FIN	4			
3	P56294	H-0500-04	1/2" FLATWASHER	4			
4	P59381	P-0812-01	ASD-45 BODY	1			
5	P59383S	P-0813-01P-UB	ASD-45 PND. KPR./LONG U-BOLT	1			
6	P61134	M-111-3	LONG COTTER PIN	1			
7	P56399	H-0520-04	1/2" LOCKWASHER	4			

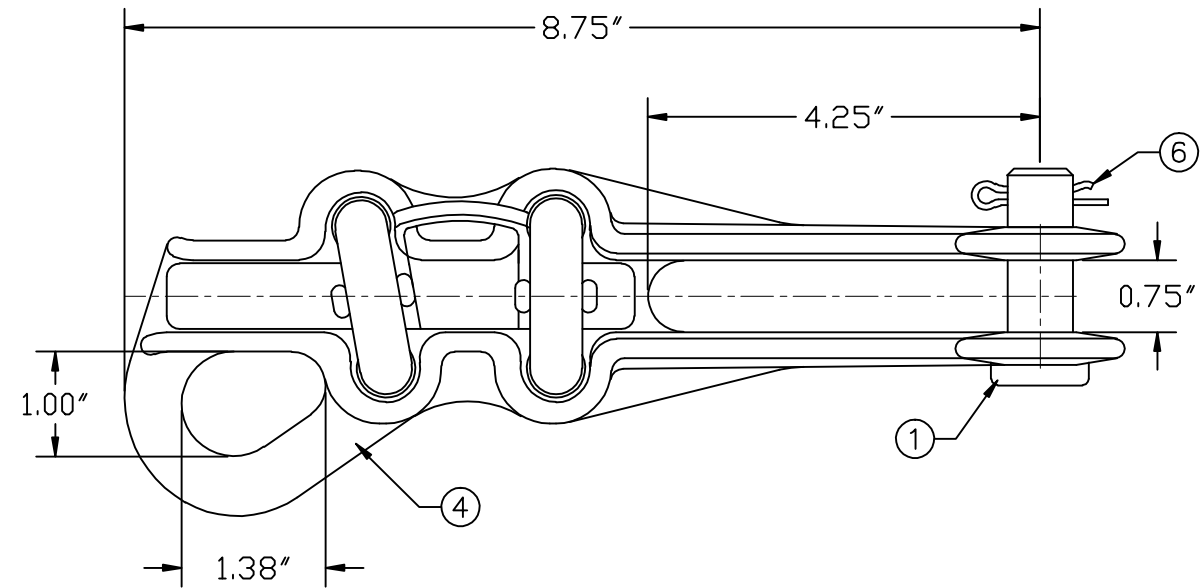

ASSEMBLY NUMBER	REF. NO.
ASD-45NLW-LKPUB	A
	B
	C
	D

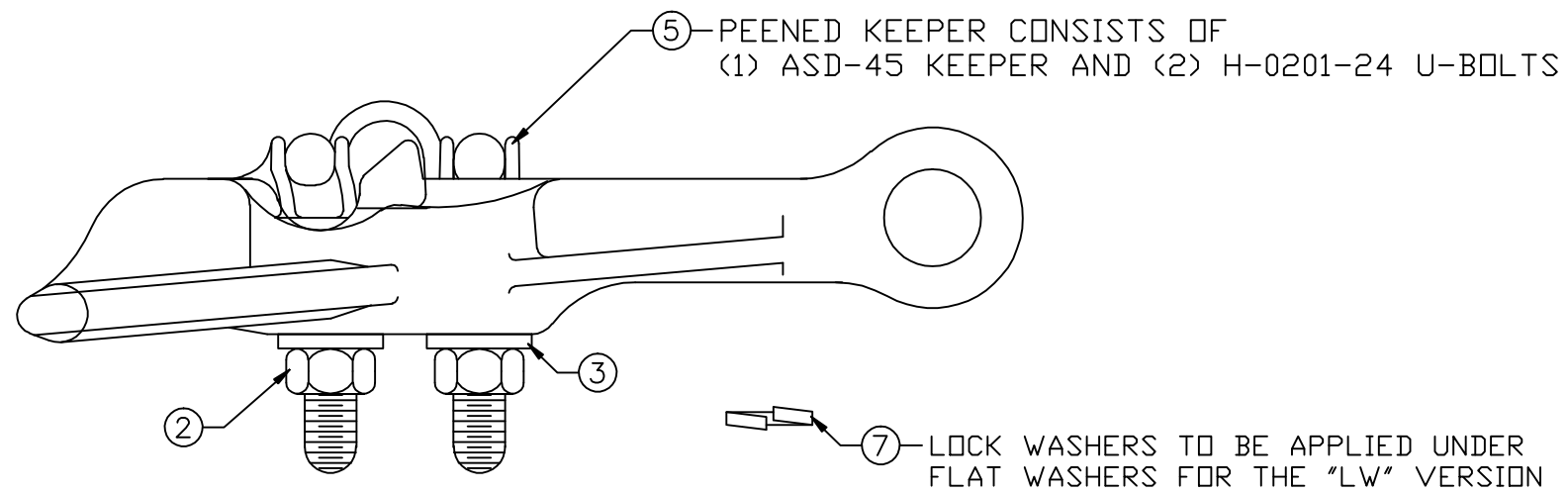

- NOTES:
- MATERIAL - BODY AND KEEPER:
A356-T6 ALUMINUM ALLOY
 - ULTIMATE STRENGTH - BODY: 10,000 LBS.
EYE: 10,000 LBS.
 - CLAMPING RANGE - 0.52" TO 0.90"
- HARDWARE:
STEEL, HOT DIP GALVANIZED PER
ASTM-A153
- COTTER PIN:
STAINLESS STEEL

MACLEAN POWER SYSTEMS
A Maclean-fogg Company

STRAIGHT STRAIN CLAMP
ASD-45NLW-LKPUB

ENG. REF.

This information is confidential and is the property of Maclean Power Systems. It may not be made public or reproduced except that the Customer may make copies for use solely in installation, maintenance, and operation of products supplied by Maclean Power Systems.

DATE: 12/14/2011	SCALE: NONE	NO. BC8553-3	R / 0	SH. 1 OF 1
DWN. BY: CDR	CKD. BY:	APR. BY:		