

REVISIONS				
NO.	DATE	DESCRIPTION	BY	CKD

ITEM NO.	PART NO.	CAT. NO.	DESCRIPTION	QUANTITY			
				A	B	C	D
1	P56137	H-0400-04	1/2"-13 HEX NUT FIN	4	4	4	
2	P56294	H-0500-04	1/2" FLATWASHER	4	4	4	
3	P59383	P-0813-01-P	ASD-45 PEENED KEEPER	1	1	1	
4	P59442	P-1047-01	TSG-90 BODY MACH	1	1	1	
5	P60279	H-0480-02	CONICAL COMPRESSION SPRING	-	1	2	

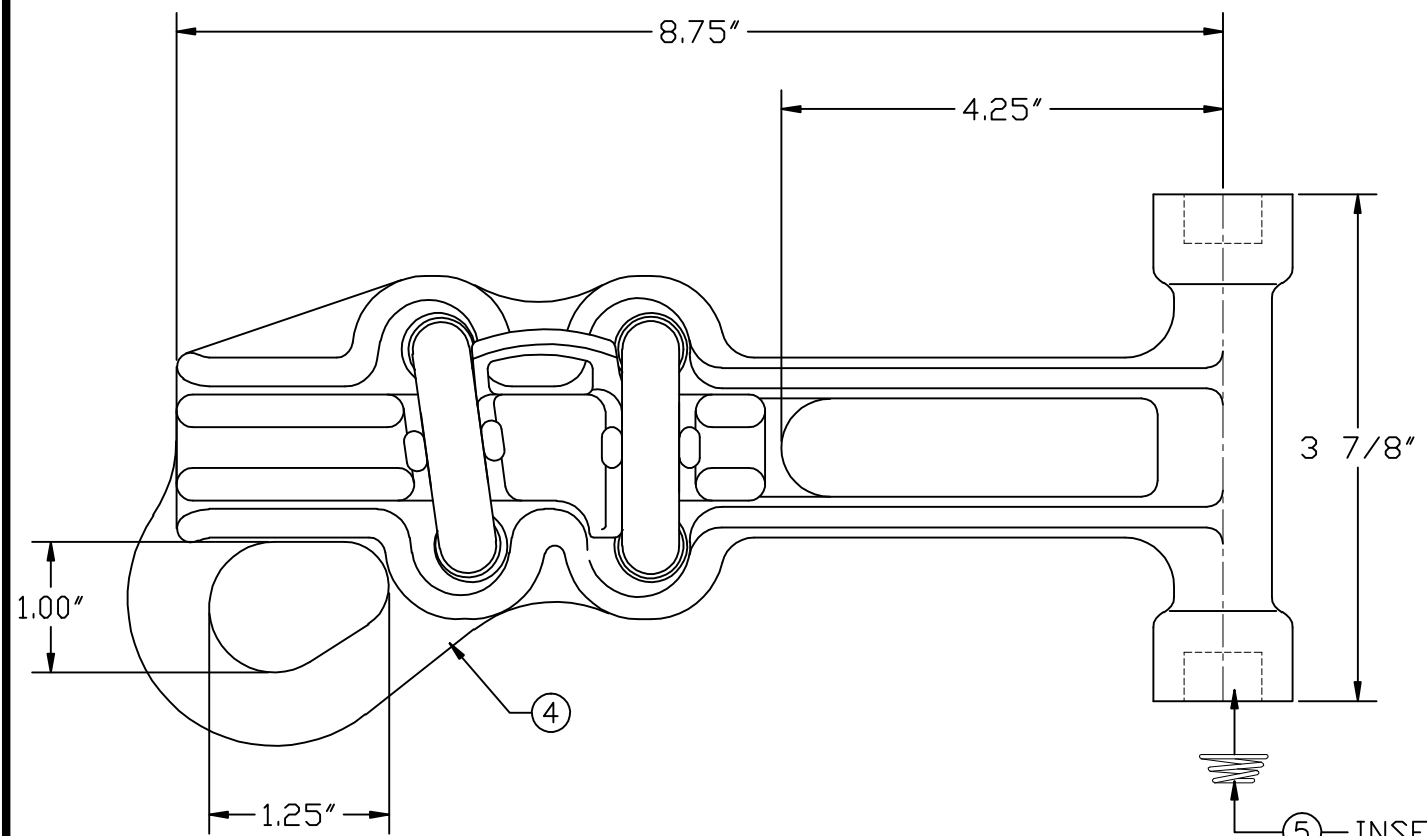

ASSEMBLY NUMBER	REF. NO.
TSG-90	A
TSG-90-SL-1	B
TSG-90-SL-2	C
	D

⑤-INSERT SPRING(S) FOR SL1 & SL2 VERSION

③-PEENED KEEPER CONSIST OF:
(1) AD-45 KEEPER (2) H-0201-07 U-BOLT

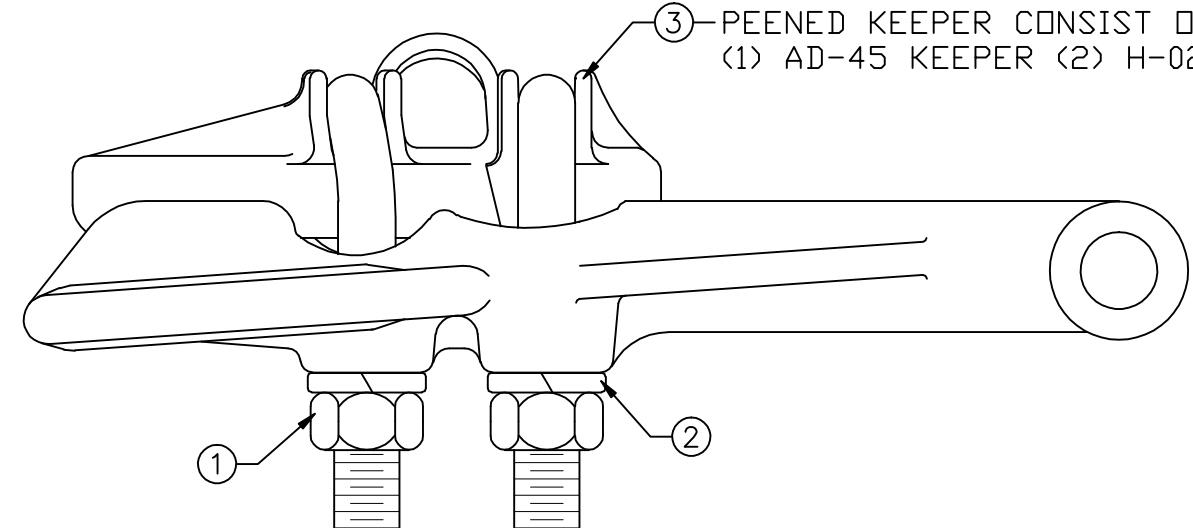

- NOTES:
- MATERIAL - BODY AND KEEPER: A356-T6 ALUMINUM ALLOY

HARDWARE: STEEL, HOT DIP GALVANIZED PER ASTM-A153

COTTER PIN & COMP. SPRING: STAINLESS STEEL
 - ULTIMATE STRENGTH - BODY: 5,000 LBS.
EYE: 5,000 LBS.
 - CLAMPING RANGE - 0.45" TO 0.90"

MACLEAN POWER SYSTEMS
A Maclean-fogg Company

SLACK SPAN STRAIGHT STRAIN CLAMP
TSG-90, TSG-90-SL-1, TSG-90-SL-2

This information is confidential and is the property of Maclean Power Systems. It may not be made public or reproduced except that the Customer may make copies for use solely in installation, maintenance, and operation of products supplied by Maclean Power Systems.

ENG. REF.