

REVISIONS				
NO.	DATE	DESCRIPTION	BY	CKD

ITEM NO.	PART NO.	CAT. NO.	DESCRIPTION	QUANTITY			
				A	B	C	D
1	P56137	H-0400-04	1/2"-13 HEX NUT FIN	4	4	4	
2	P56294	H-0500-04	1/2" FLATWASHER	4	-	4	
3	P59388	P-0815-01-P	ASD-58 PEENED KEEPER	1	1	1	
4	P59439	P-1044-01	TSG-125 BODY CAST	1	1	1	
5	P56399	H-0520-04	1/2" LOCKWASHER	-	4	-	
6	P60279	H-0480-02	CONICAL COMPRESSION SPRING	-	-	1	

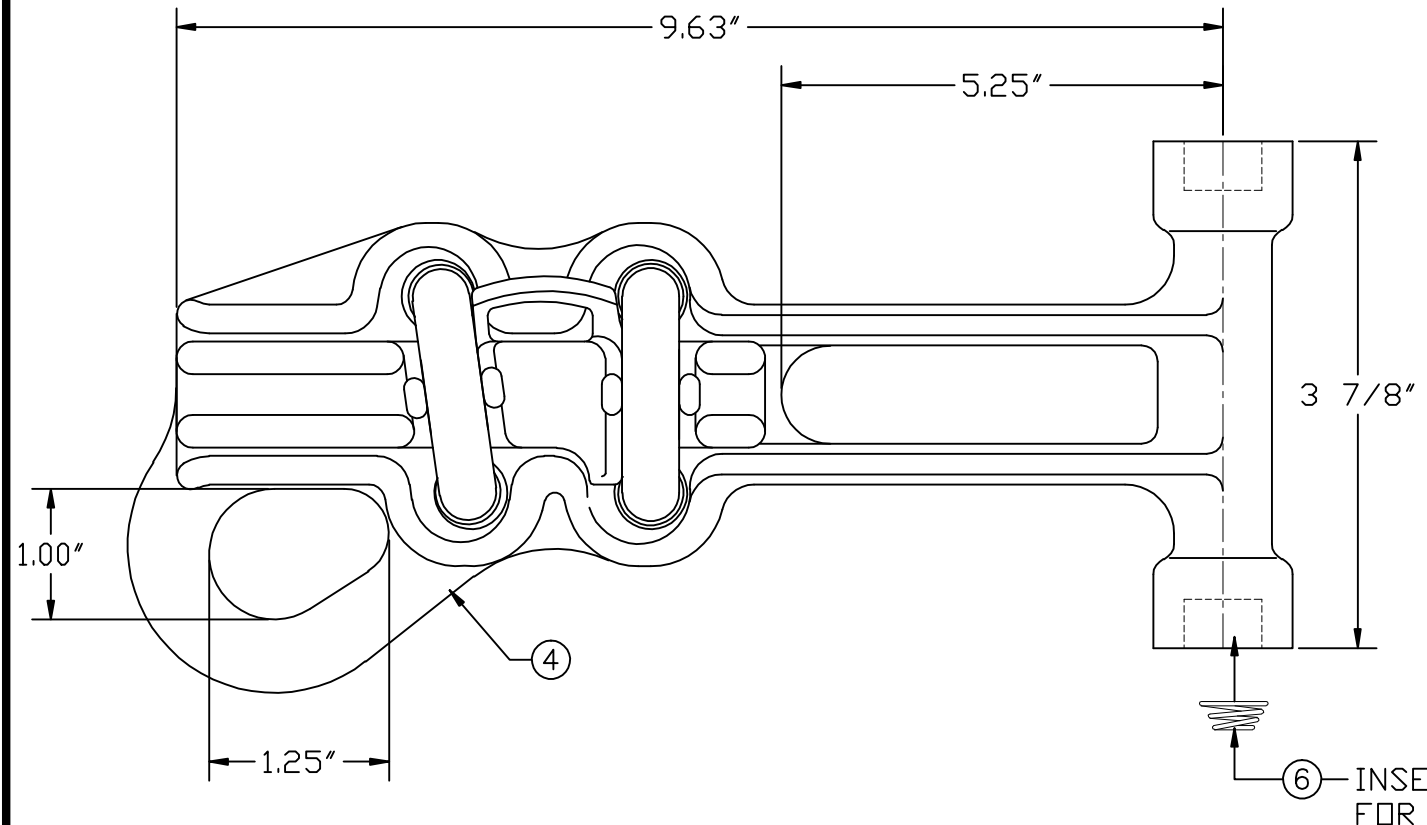

ASSEMBLY NUMBER	REF. NO.
TSG-125	A
TSG-125-L/W	B
TSG-125-SL-1	C
	D

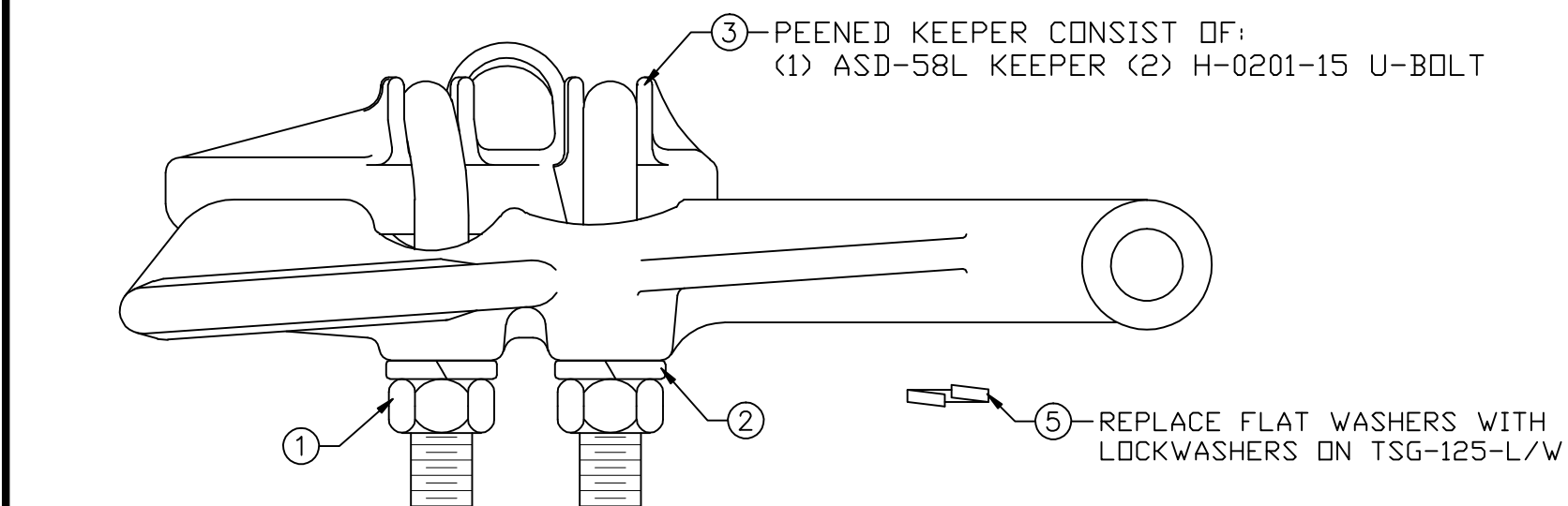

NOTES:

1. MATERIAL - BODY AND KEEPER:  
A356-T6 ALUMINUM ALLOY

HARDWARE:  
STEEL, HOT DIP GALVANIZED PER  
ASTM-A153

COTTER PIN & COMP. SPRING:  
STAINLESS STEEL

2. ULTIMATE STRENGTH - BODY: 5,000 LBS.  
EYE: 5,000 LBS.

3. CLAMPING RANGE - 0.62" TO 1.25"

**MACLEAN POWER SYSTEMS**  
A Maclean-fogg Company

SLACK SPAN STRAIGHT STRAIN CLAMP  
TSG-125, TSG-125-L/W, TSG-125-SL-1