

REVISIONS				
NO.	DATE	DESCRIPTION	BY	CKD

ITEM NO.	PART NO.	CAT. NO.	DESCRIPTION	QUANTITY			
				A	B	C	D
1	P56046	H-0241-02	1/2" SEMSBOLT	2	2	2	
2	P59012	P-0423-01	ACTS-230 BODY MAC	1	1	1	
3	P59014	P-0423-02	ACTS-230 KEEPER	1	1	1	
4	P60279	H-0480-02	CONICAL COMPRESSION SPRING	-	1	2	

ASSEMBLY NUMBER	REF. NO.
ACTS-230	A
ACTS-230-SL1	B
ACTS-230-SL2	C
	D

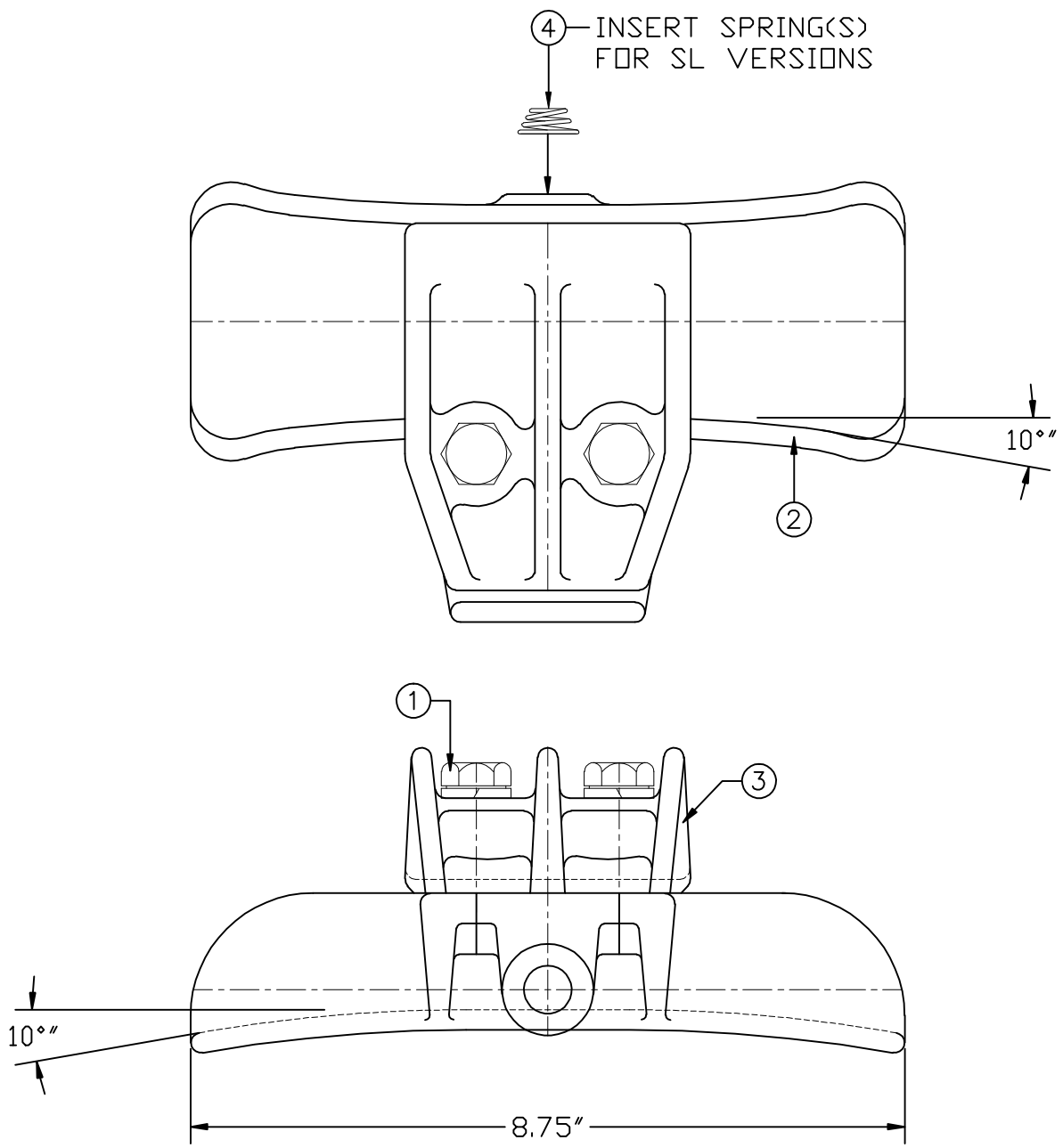

- NOTES:
- MATERIAL - BODY AND KEEPER:
A356-T6 ALUMINUM ALLOY
 - HARDWARE:
STEEL, HOT DIP GALVANIZED PER
ASTM-A153
 - SPRING:
STAINLESS STEEL
- ULTIMATE STRENGTH: 5,000 LBS.
 - CLAMPING RANGE - 1.90" TO 2.30"

MACLEAN POWER SYSTEMS
A Maclean-fogg Company

TOP LINE POST INSULATOR CLAMP
ACTS-230, ACTS-230-SL1, ACTS-230-SL2

This information is confidential and is the property of Maclean Power Systems. It may not be made public or reproduced except that the Customer may make copies for use solely in installation, maintenance, and operation of products supplied by Maclean Power Systems.

ENG. REF.

DATE: 12/28/2011	SCALE: NONE	NO. BC8585-1	R/0	SH. 1 OF 1
DWN. BY: CDR	CKD. BY:	APR. BY:		