

PAPER SIZE		DRAWING NUMBER	
<b>C</b>		<b>G45</b>	
REV	REVISED BY:	REVISION DATE	ECO #
X	XXX	XX/XX/XX	XXX
X	XXX	XX/XX/XX	XXX

**4.5" (0.290" wall) PRESSURE GROUTED DISPLACEMENT PILE  
(torque rating 32,000 ft-lbs)**

**Notes:**

- Bolted sleeve couplers.
- Estimated grout column diameter of 10" to 16" equal to driver plate (H1) diameter
- Grout port at nose of pile, pressure grouted through ID of pile during installation
- Grout shall have a minimum compression strength of 4,000 psi
- Grout shall be pumped below the maximum pressure of 350 psi during installation
- Shaft Material - OCTG pipe - 80 ksi min yield
- Driver Plate Material - Hot rolled low carbon steel per ASTM A572 Grade 50 minimum
- Connection Hardware - Bolts per ASTM A325. Jam nuts per A563. Hot dipped galvanized per ASTM A153
- All welds performed by welders certified by AWS code D1.1
- All driver plates formed with nominal 6" pitch
- Products Hot Dipped Galvanized per ASTM A123 following fabrication. Non-galvanized products are designated with a "U" catalog number suffix.
- Custom lead and extension lengths up to 40' and driver plate configurations available upon request

Catalog Number	Length1 (ft)	H1 (in)	Grout Take (yd3/LF)	Ult Tension (kips)	Ult Compression (kips)
G45L15T16	15	16	0.05	169	371
G45L15T14		14	0.04		318
G45L15T12		12	0.03		272
G45L15T10		10	0.02		234

Catalog Number	Length2 (ft)
H45E20	20
H45E15	15
H45E10	10

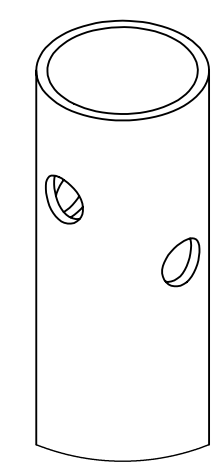

DETAIL A  
SCALE 1 : 5

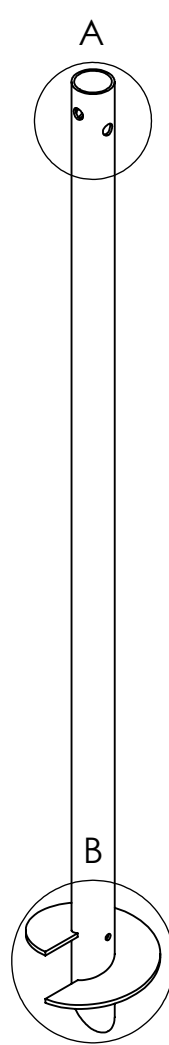

DETAIL B  
SCALE 1 : 5

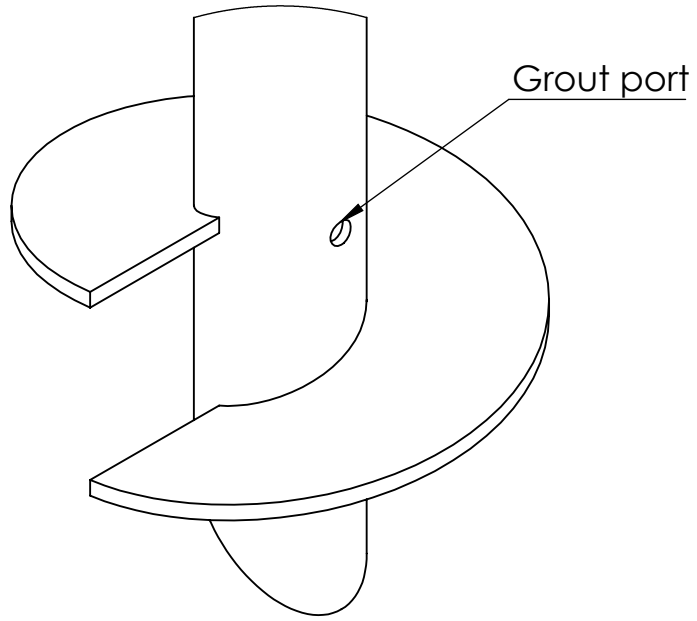

Grout port

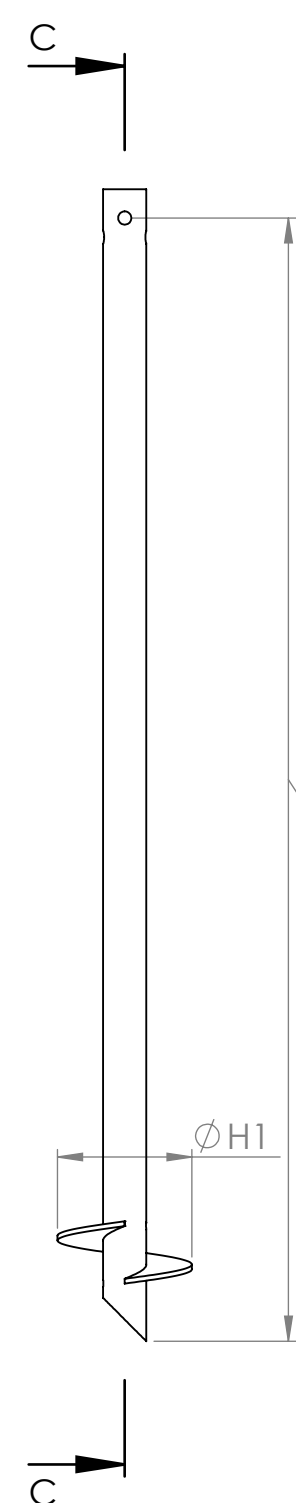

Length1

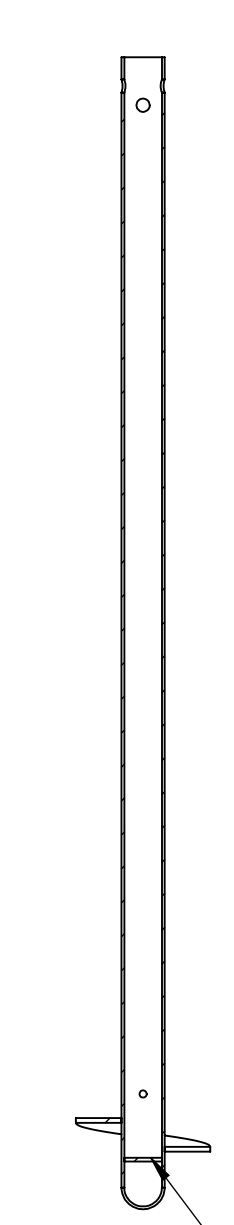

Steel plate grout plug welded to ID of pipe

SECTION C-C

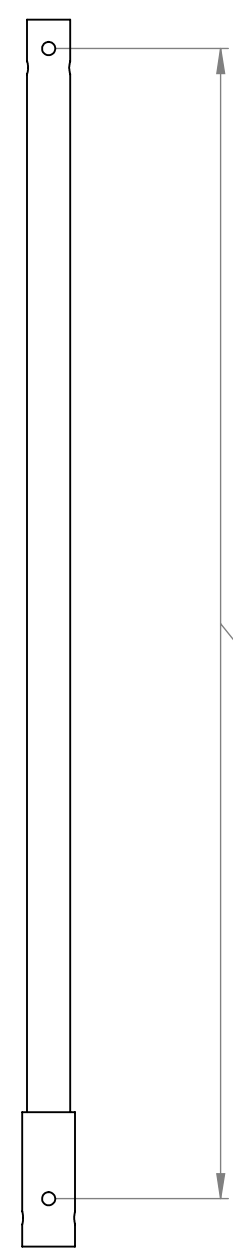

Length2

USE OR REPRODUCTION OF THIS DRAWING FOR THE PURPOSE OF MANUFACTURING THIS ARTICLE OR ARTICLES SHOWN OR ANY OTHER PURPOSE IS STRICTLY PROHIBITED EXCEPT ON WRITTEN PERMISSION \*\*MACLEAN POWER SYSTEMS\*\*

**MACLEAN  
POWER  
SYSTEMS**  
1465 INDUSTRIAL PARK DR  
TRENTON, TN 38382  
TEL. (731) 470-3400 FAX: (731) 470-3402

DRAWING NUMBER: <b>G45</b>	DO NOT SCALE DRAWING
SHEET NAME: <b>Sheet1</b>	CAD GENERATED DRAWING DO NOT MANUALLY UPDATE
DRAWING DESCRIPTION: 4.5" bolted coupler grouted piles	DESIGN DATE: <b>01/04/22</b>
DRAWING SCALE: 1:20	DRAWN BY: DR
	ENGINEER: DR
	APPROVED: XXX
	REF DWG: X