

PAPER SIZE		DRAWING NUMBER	
B		GD-7653CRS	
REV	REVISED BY	REVISION DATE	ECO #
A	CAN	04-15-20	D9885
B	ZHB	06-28-21	D10235

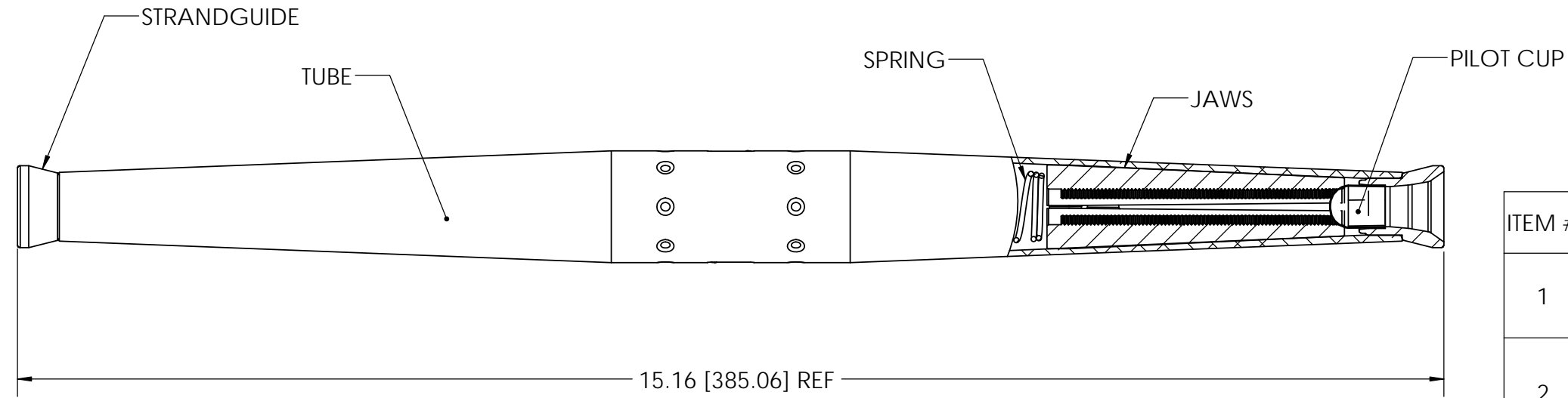

ITEM #	DESCRIPTION	MATERIAL	QUANTITY
1	TUBE	ALUMINUM ALLOY	1
2	JAW	DIE CAST ALUMINUM ALLOY	4
3	SPRING	STAINLESS STEEL	2
4	CENTER TAB	PLASTIC (GREEN)	1
5	PILOT CUP	ALUMINUM	2
6	STRAND GUIDE	PLASTIC (YELLOW)	2

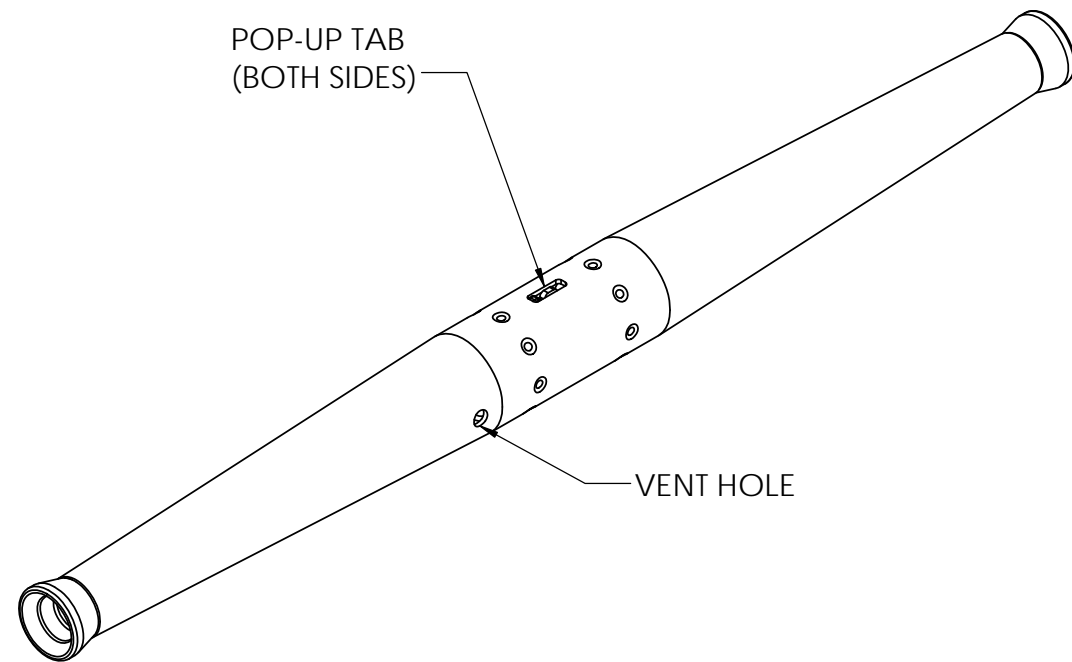
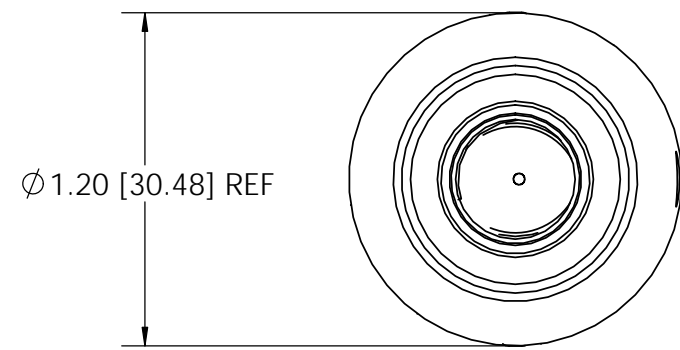

WIRE RANGE	
ACSR ASTM-B232	1/0
AAAC ASTM-B399	1/0
AAC ASTM-B231	1/0 & 2/0
DIAMETER RANGE	.365-.425

CATALOG #	7653CRS
-----------	---------

Notes:

1. Connector is rated to hold a minimum of 95% of the RBS of the strand used.
2. Dimensions are in inches with millimeters noted in brackets.
3. All dimensions are reference.
4. Standard pack is 50.
5. Current Class A (Heavy Duty) and Tension Class 1 (Full Tension) per ANSI C119.4.

This drawing contains confidential information that is the property of MacLean Power, L.L.C. ("MacLean"). Use of MacLean's confidential information without MacLean's express written consent is strictly prohibited and may expose you to legal liability. If you believe that you received this material in error, please destroy it or return it to "MacLean Power, L.L.C., 11411 Addison Street, Franklin Park, Illinois 60131, USA."

UNLESS OTHERWISE SPECIFIED DIMENSIONS ARE IN:	
INCHES	
TOLERANCES ARE:	
.X	+/- 0.1
.XX	+/- 0.03
.XXX	+/- .015
ANGLES	+/- 1.0°

DRAWING NUMBER: GD-7653CRS		DO NOT SCALE DRAWING	
SHEET NAME: 7653CRS		CAD GENERATED DRAWING DO NOT MANUALLY UPDATE	
1 OF 1		DESIGN DATE: 04-16-18	
DRAWING DESCRIPTION: 7653 CRS AUTOMATIC ACSR TENSION SPLICE, CORROSION RESISTANT WITH POP OUT TABS		DRAWN BY:	ZHB
		ENGINEER:	SJL
		APPROVED:	MG
DRAWING SCALE: NONE			