

PAPER SIZE		DRAWING NUMBER	
<b>B</b>		<b>GD-7659CRS</b>	
REV	REVISED BY	REVISION DATE	ECO #
A	CAN	04-15-20	D9885
B	ZHB	06-30-21	D10235

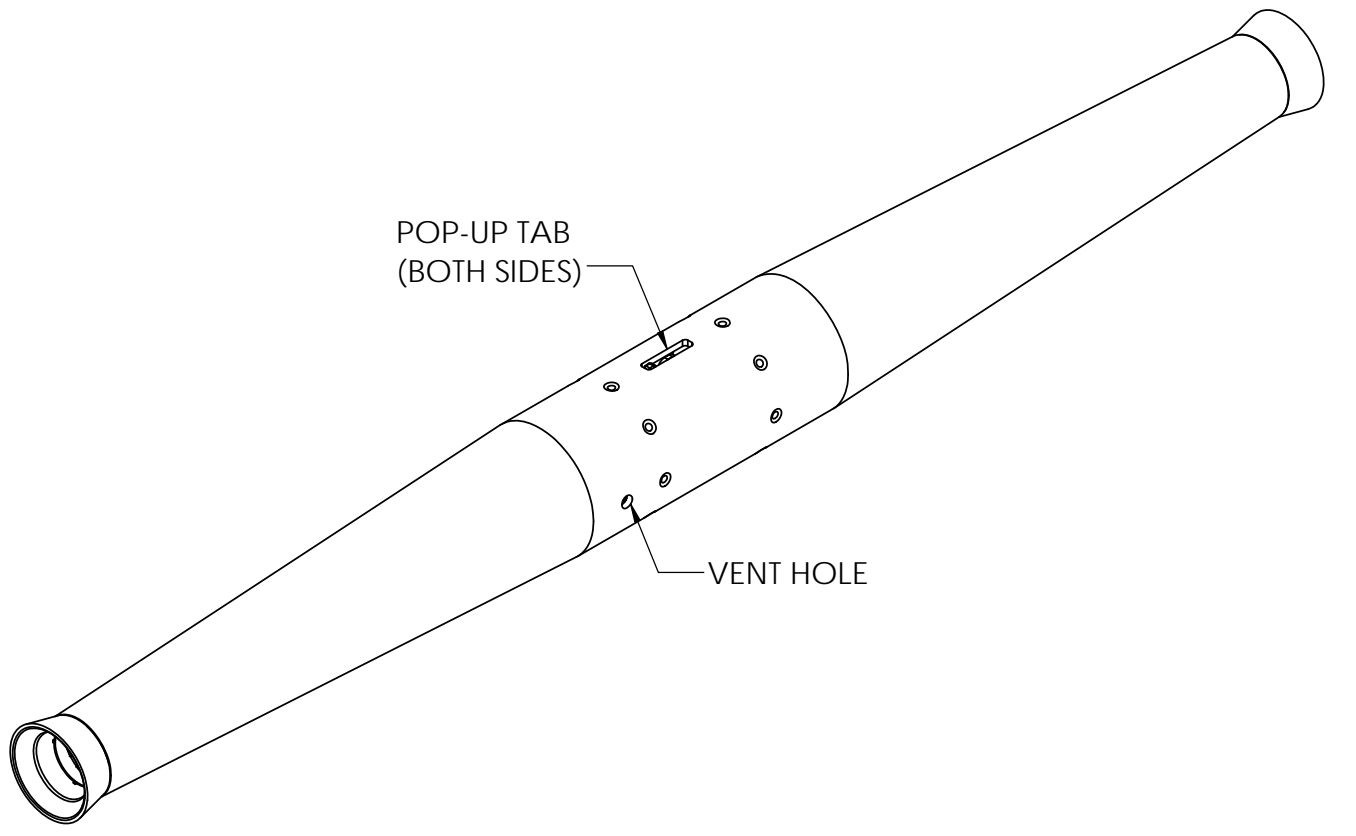
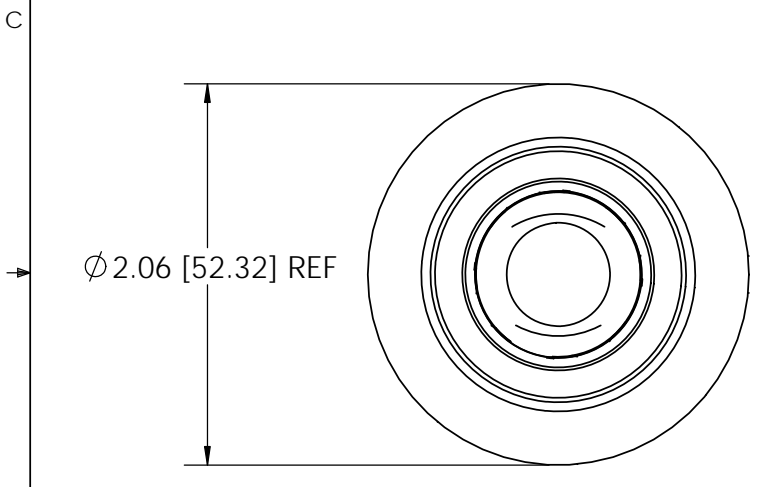
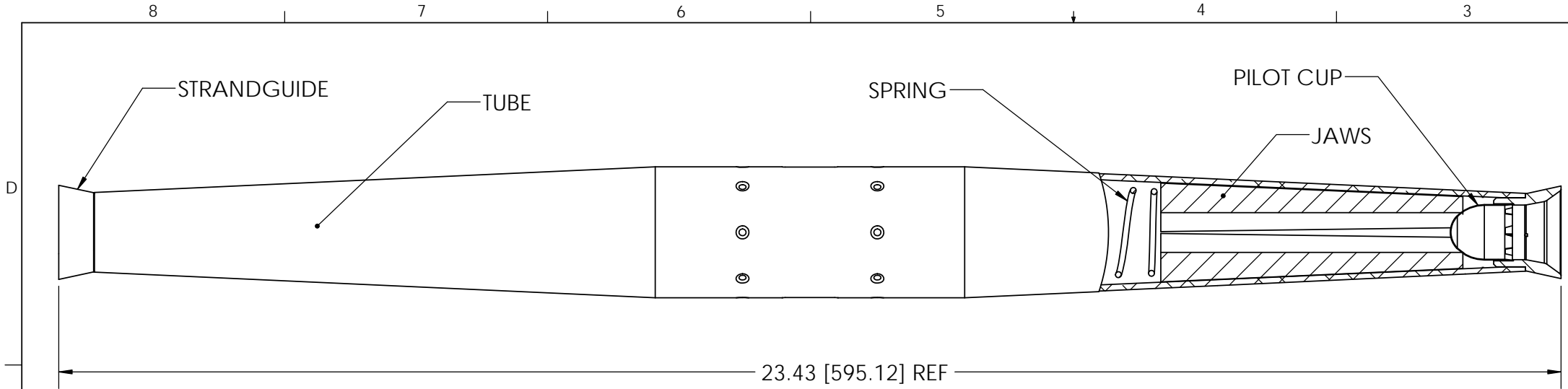

ITEM #	DESCRIPTION	MATERIAL	QUANTITY
1	TUBE	ALUMINUM ALLOY	1
2	JAW	DIE CAST ALUMINUM ALLOY	4
3	SPRING	STAINLESS STEEL	2
4	CENTER TAB	PLASTIC (GREEN)	1
5	PILOT CUP	ALUMINUM	2
6	STRAND GUIDE	PLASTIC (AQUA)	2

WIRE RANGE	
ACSR ASTM-B232	397.5 -18/1 477-18/1
AAAC ASTM-B399	397.5 & 477
AAC ASTM-B231	397.5, 477 & 556.5
DIAMETER RANGE	.740 - .856

CATALOG #	7659CRS
-----------	---------

- Notes:**
1. Connector is rated to hold a minimum of 95% of the RBS of the strand used.
  2. Connector is rated for a maximum tension of 12,500 lbs for 556.5 AAC.
  3. Dimensions are in inches with millimeters noted in brackets.
  4. All dimensions are reference.
  5. Standard pack is 10.
  6. Current Class A (Heavy Duty) and Tension Class 1 (Full Tension) per ANSI C119.4.

This drawing contains confidential information that is the property of MacLean Power, L.L.C. ("MacLean"). Use of MacLean's confidential information without MacLean's express written consent is strictly prohibited and may expose you to legal liability. If you believe that you received this material in error, please destroy it or return it to "MacLean Power, L.L.C., 11411 Addison Street, Franklin Park, Illinois 60131, USA."

UNLESS OTHERWISE SPECIFIED DIMENSIONS ARE IN:	
<b>INCHES</b>	
TOLERANCES ARE:	
.X	+/- 0.1
.XX	+/- 0.03
.XXX	+/- .015
ANGLES	+/- 1.0°

DRAWING NUMBER: <b>GD-7659CRS</b>		DO NOT SCALE DRAWING	
SHEET NAME: <b>7659CRS</b>		CAD GENERATED DRAWING DO NOT MANUALLY UPDATE	
1 OF 1		DESIGN DATE: <b>04-16-18</b>	
DRAWING DESCRIPTION: 7659 CRS AUTOMATIC ACSR TENSIONS SPLICE, CORROSION RESISTANT WITH POP OUT TAB		DRAWN BY:	<b>ZHB</b>
		ENGINEER:	<b>SJL</b>
		APPROVED:	<b>MG</b>
DRAWING SCALE:		NONE	