

ITEM NO.	QTY.	DESCRIPTION
1	1	.18 X 1.50 CLEVIS BODY
2	1	.625 X 4.50 BUTTON HEAD BOLT
3	1	SELF LOCKING COTTER PIN
4	1	NUMBER 24 WOOD SCREW

PAPER SIZE		CATALOG NUMBER	
<b>B</b>		<b>J075</b>	
REV	REVISED BY	REVISION DATE	ECO #
A	-	10-08-09	9679
B	JAM	12-15-21	D10376

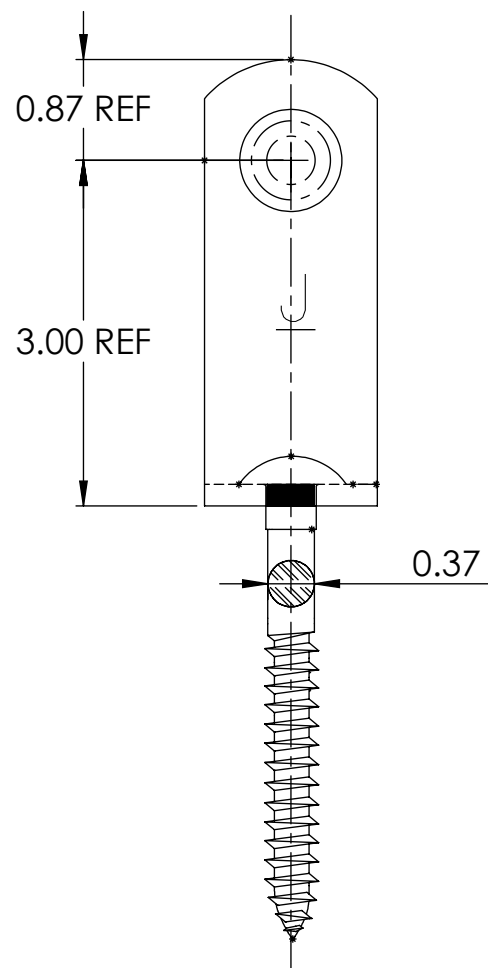
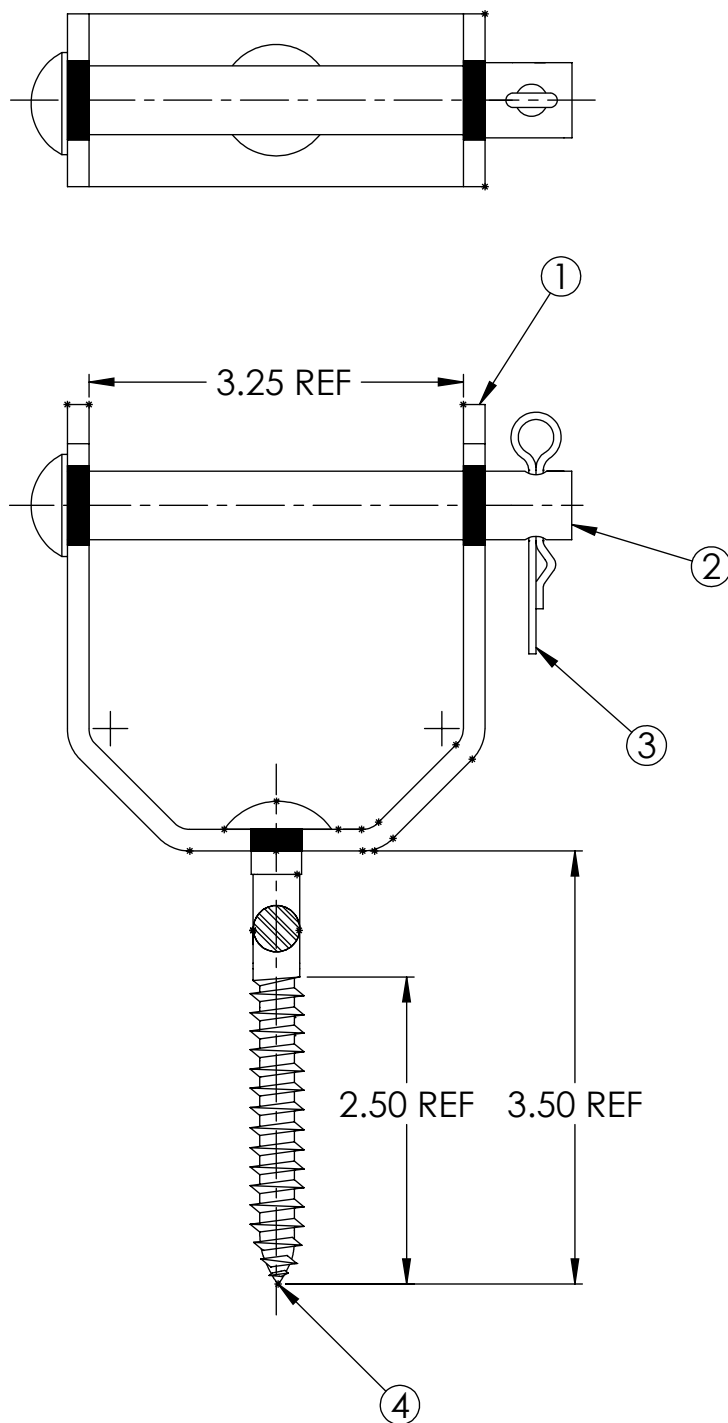

NOTES:

1. ALL DIMENSIONS ARE REFERENCE AND IN INCHES
2. ALL ITEMS ARE HOT DIP GALVANIZED PER ASTM A-153 EXCEPT ITEM 3
3. ITEM 3 IS STAINLESS STEEL

This drawing contains confidential information that is the property of MacLean Power, L.L.C. ("MacLean"). Use of MacLean's confidential information without MacLean's express written consent is strictly prohibited and may expose you to legal liability. If you believe that you received this material in error, please destroy it or return it to "MacLean Power, L.L.C., 481 Munn Rd, Suite 300, Fort Mill, SC 29715 USA."



DRAWING NUMBER: <b>GD-J075</b>	
SHEET NAME: <b>J075</b>	2 OF 2
DRAWING DESCRIPTION: CLEVIS WITH LAG SCREW	
DRAWN BY: JAM	DESIGN DATE: