

PAPER SIZE		CATALOG NUMBER	
B		GD-J1118A	
REV	REVISED BY	REVISION DATE	ECO #
A	JAM	10-06-17	D8815

D
C
B
A

D
C
B
A

This drawing contains confidential information that is the property of MacLean Power, L.L.C. ("MacLean"). Use of MacLean's confidential information without MacLean's express written consent is strictly prohibited and may expose you to legal liability. If you believe that you received this material in error, please destroy it or return it to "MacLean Power, L.L.C., 481 Munn Rd, Suite 300, Fort Mill, SC 29715 USA."

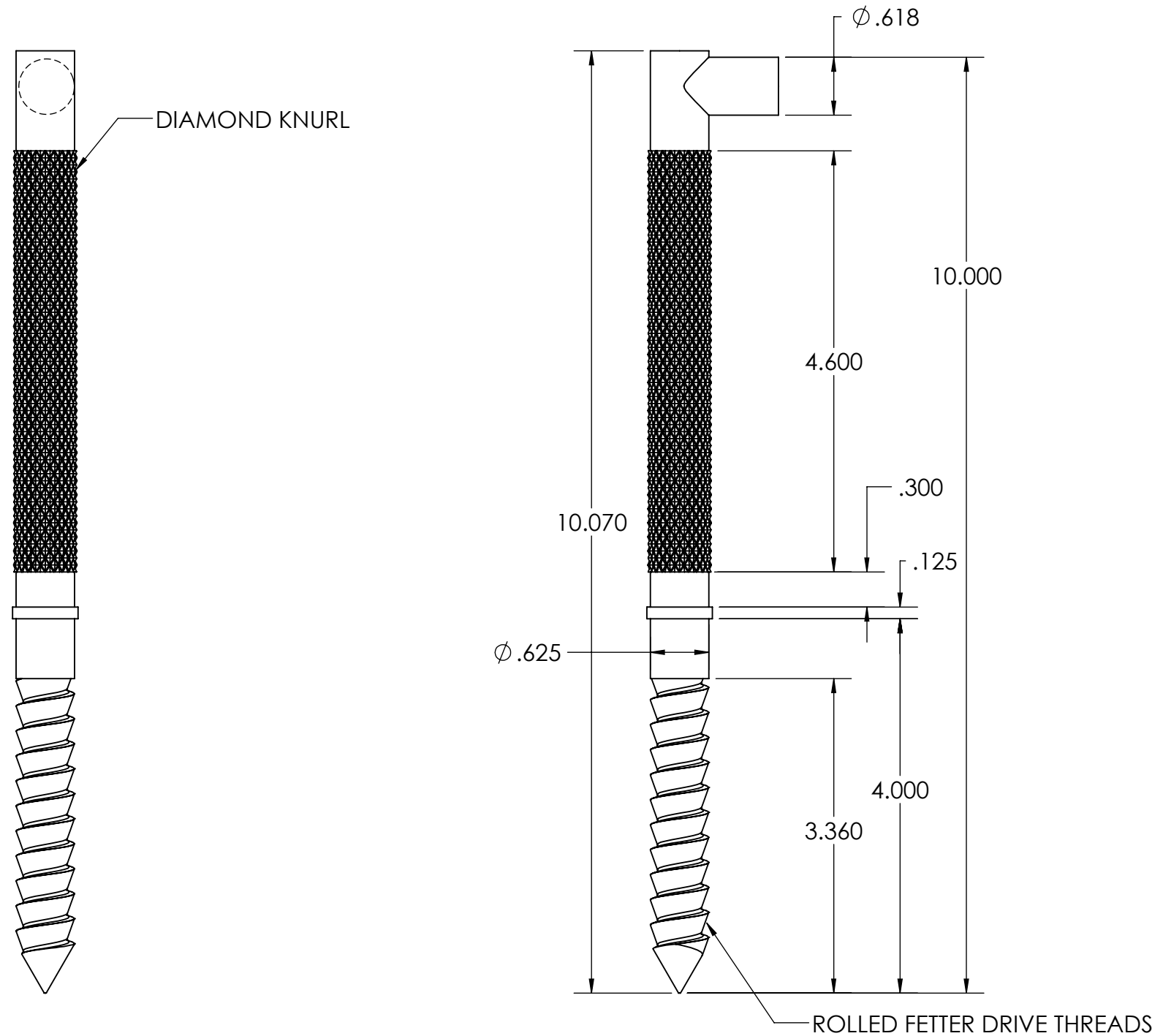
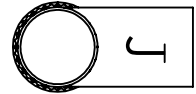

MATERIAL:
HOT ROLLED CARBON STEEL PER AISI, GRADE 1020

- NOTES:
1. ALL DIMENSIONS ARE IN INCHES
 2. HOT DIP GALVANIZED PER ASTM A 153.

PART NO. F-102918
CATALOG NO. J1118A

**MACLEAN
POWER
SYSTEMS**
WWW.MACLEANPOWER.COM

DRAWING NUMBER: GD-J1118A	
SHEET NAME: Sheet1	1 OF 1
DRAWING DESCRIPTION: KNURLED POLE STEP	
DRAWN BY: SRA	DESIGN DATE: 2/21/13

8 7 6 5 4 3 2 1