

ITEM NO.	QTY.	DESCRIPTION
1	1	.12 X 2.75 CLEVIS BODY
2	1	.625 X 4.50 BUTTON HEAD BOLT

PAPER SIZE		CATALOG NUMBER	
B		J250	
REV	REVISED BY	REVISION DATE	ECO #
A	-	9-23-09	9718
B	JAM	02-08-22	D10376

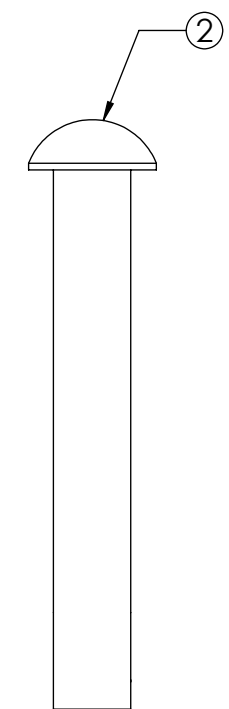
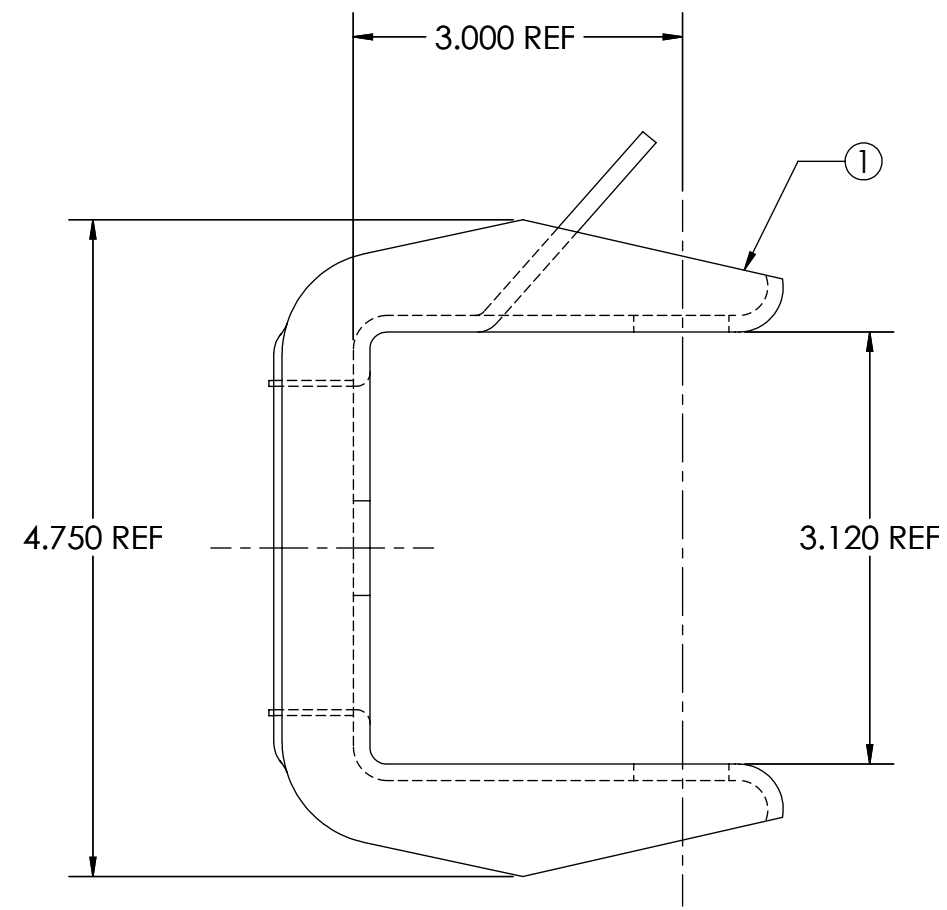
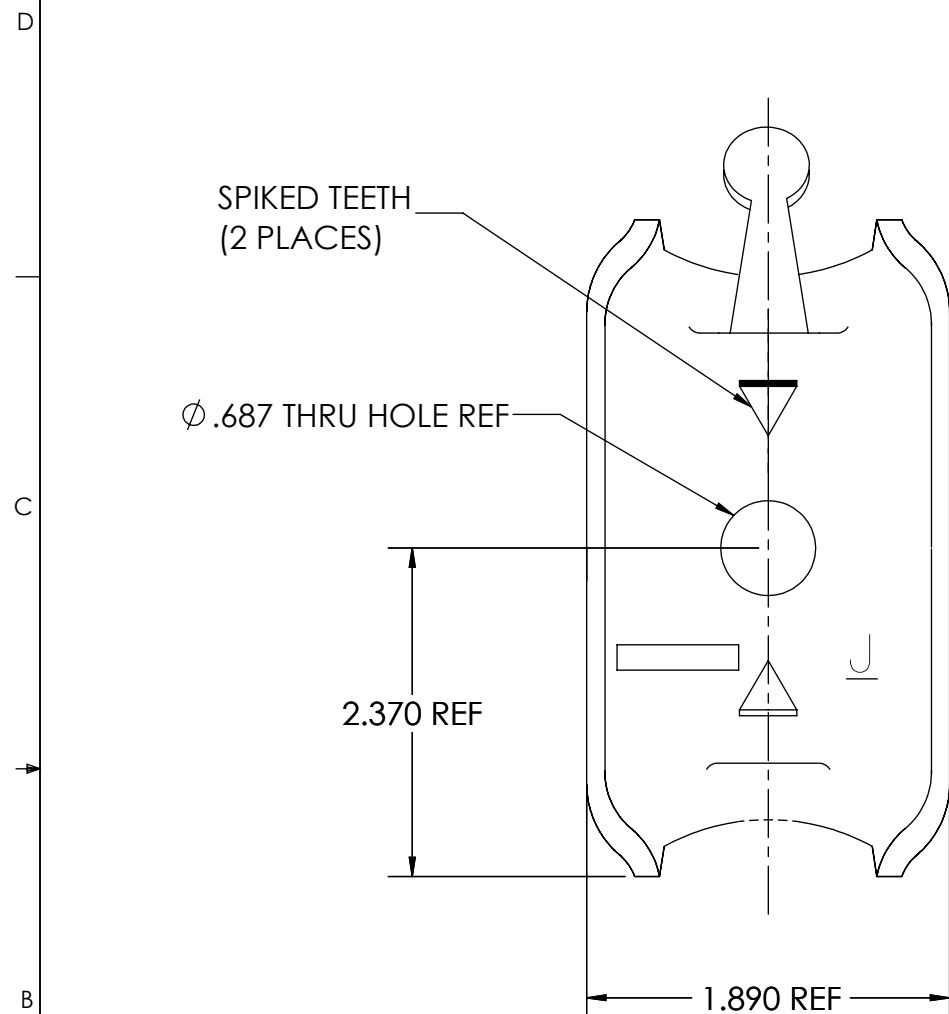

NOTES:

1. ALL DIMENSIONS ARE REFERENCE AND IN INCHES
2. ALL ITEMS HOT DIP GALVANIZED PER ASTM A-153.

This drawing contains confidential information that is the property of MacLean Power, L.L.C. ("MacLean"). Use of MacLean's confidential information without MacLean's express written consent is strictly prohibited and may expose you to legal liability. If you believe that you received this material in error, please destroy it or return it to "MacLean Power, L.L.C., 481 Munn Rd, Suite 300, Fort Mill, SC 29715 USA."

MacLeanTM
POWER SYSTEMS
WWW.MACLEANPOWER.COM

DRAWING NUMBER: GD-J250	
SHEET NAME: Model	1 OF 2
DRAWING DESCRIPTION: CLEVIS	
DRAWN BY: JAM	DESIGN DATE: