

MPS Catalog Number:

Date:

**H1 90 10 030 CX SS 017**

05/20/2021

**End Fittings**

Tower End Fitting:

Gain / 12 deg / Steel

Line End Fitting:

Anchor / Ductile Iron  
2 HL Drop Tongue / Ductile Iron

**Material**

Corona Ring (Tower):

None

Corona Ring (Line):

None

Corona Rings are recommended for applications of 230 kV and above

Mounting Angle:

12 deg

Number of Sheds:

17

Rod Diameter:

2 in

Weight Estimate:

53.6 lbs

24 kg

**Dimensional Values**

Section Length (L):

39.7 in 1,008 mm

Rubber Length (X):

30 in 762 mm

Shed spacing (S):

1.6 in 41 mm

Shed Projection (P):

2.7 in 68 mm

Dry Arc Distance:

33 in 838 mm

Leakage Distance:

116 in 2,946 mm

**Electricals Values**

60 Hz dry Flashover (Min. Withstand):

322 kV 302 kV

60 Hz Wet Flashover (Min. Withstand):

297 kV 231 kV

CIFO Positive (Min. Withstand):

550 kV 493 kV

CIFO Negative (Min. Withstand):

643 kV 529 kV

**Mechanical Values**

Max. Design Cant. Load (MDCL):

1,134 lbs 5.0 kN

Specified Cant. Load (SCL):

2,268 lbs 10.1 kN

Specified Tensile Load (STL):

7,000 lbs 31.1 kN

This drawing contains confidential information that is the property of MacLean Power, L.L.C. ("MacLean"). Use of MacLean's confidential information without MacLean's express written consent is strictly prohibited and may expose you to legal liability. If you believe that you received this material in error, please destroy it or return it to "MacLean Power, L.L.C., 7801 Park Place Rd., York, South Carolina 29745, USA."

Notes:

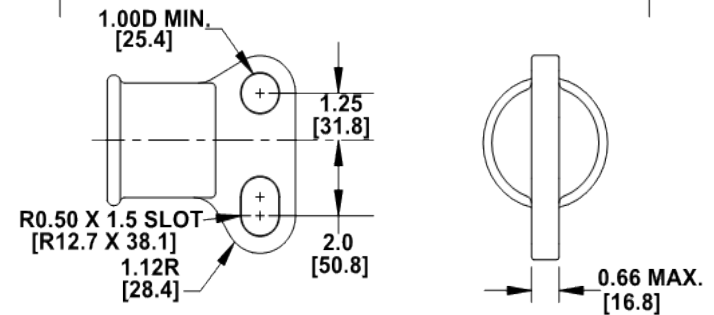
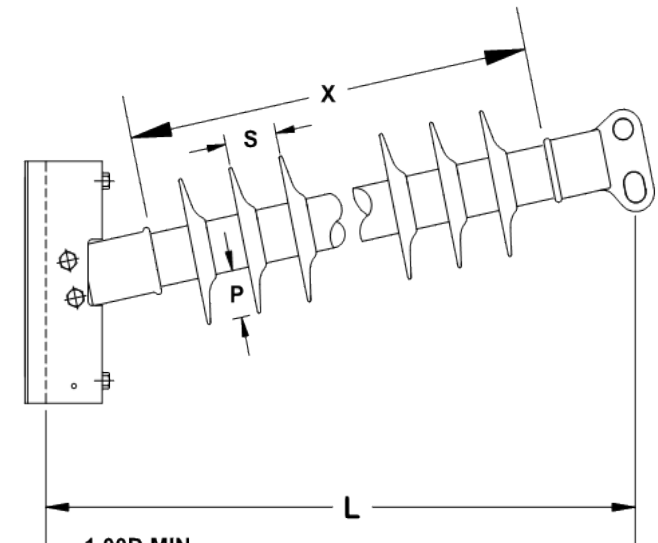
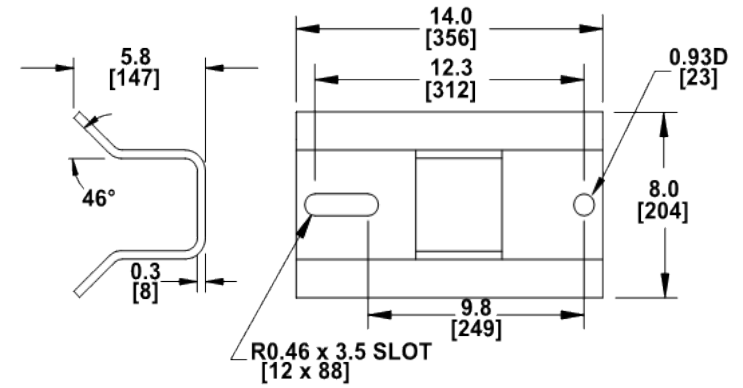

Dimension: inches [millimeters]

NOTE: Drawing not actual depiction of insulator appearance.

Silicone rubber sheath and sheds complies with applicable ANSI and IEC standards.

Prepared By: Laurel Wallace