

MPS Catalog Number:

Date:

H3 90 10 070 AX SS 027

05/20/2021

End Fittings

Tower End Fitting:

Gain/12"-14" Hole Spacing

Anchor / Galv. Ductile Iron

Line End Fitting:

2 HL Drop Tongue / Galv. Ductile Iron

Material

Corona Ring (Tower):

None

Corona Ring (Line):

None

Corona Rings are recommended for applications of 230 kV and above

Mounting Angle:

17 deg

Number of Sheds:

27

Rod Diameter:

3 in

Weight Estimate:

124 lbs

56 kg

Dimensional Values

Section Length (L):

82.4 in 2,093 mm

Rubber Length (X):

70 in 1,778 mm

Shed spacing (S):

2.5 in 64 mm

Shed Projection (P):

2.7 in 68 mm

Dry Arc Distance:

73 in 1,854 mm

Leakage Distance:

201.4 in 5,116 mm

Electricals Values

60 Hz dry Flashover (Min. Withstand):

672 kV 631 kV

60 Hz Wet Flashover (Min. Withstand):

614 kV 495 kV

CIFO Positive (Min. Withstand):

1179 kV 1040 kV

CIFO Negative (Min. Withstand):

1210 kV 1089 kV

Mechanical Values

Max. Design Cant. Load (MDCL):

1,852 lbs 8.2 kN

Specified Cant. Load (SCL):

3,704 lbs 16.5 kN

Specified Tensile Load (STL):

20,000 lbs 89.0 kN

This drawing contains confidential information that is the property of MacLean Power, L.L.C. ("MacLean"). Use of MacLean's confidential information without MacLean's express written consent is strictly prohibited and may expose you to legal liability. If you believe that you received this material in error, please destroy it or return it to "MacLean Power, L.L.C., 7801 Park Place Rd., York, South Carolina 29745, USA."

Notes:

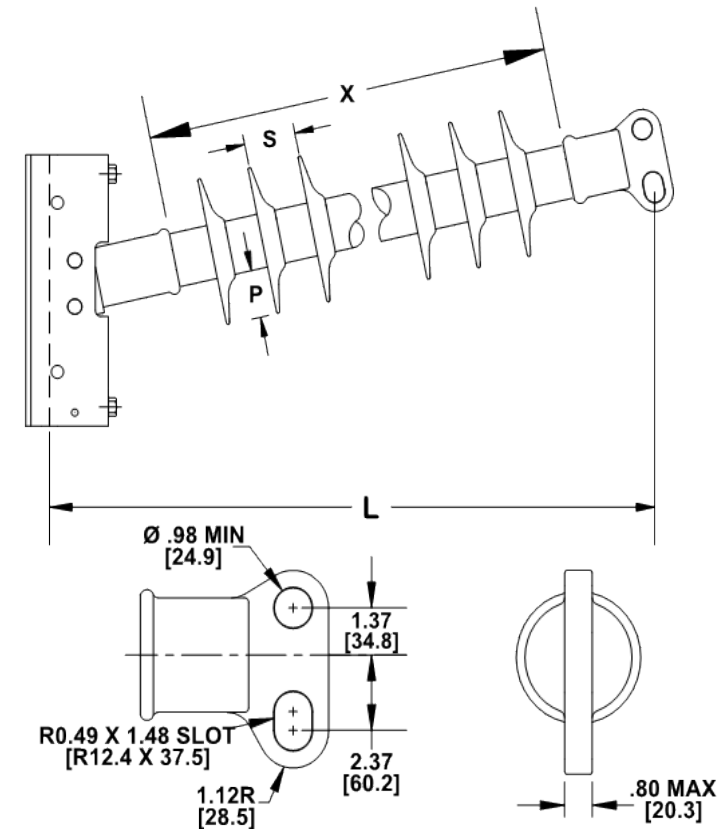
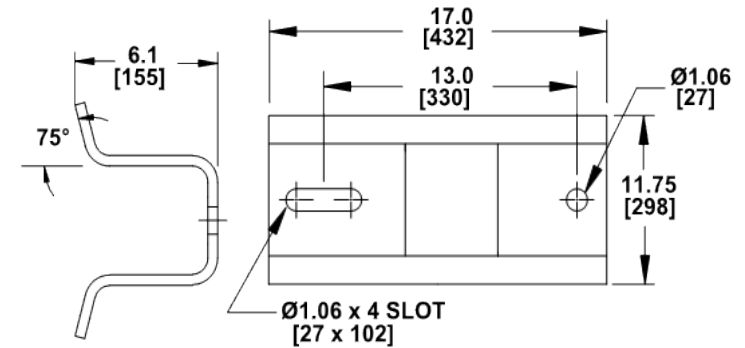

Dimension: inches [millimeters]

NOTE: Drawing not actual depiction of insulator appearance.

Silicone rubber sheath and sheds complies with applicable ANSI and IEC standards.

Prepared By: Laurel Wallace