

NPVG 20 XG O17 S0

Date 4/29/2022

End Fittings

Tower End Fitting: Gain Base VB-08/ 90 deg / Galv. Ductile Iron

Line End Fitting: Vertical Trunnion / Galv. Ductile Iron

Material

Mounting Angle: 90 deg
 Number of Sheds: 17
 Rod Diameter: 1.75 in
 Weight Estimate: 21.1 lbs 9.6 kg

Dimensional Values

Section Length (X): 26.0 in 661 mm
 Shed Diameter (B1): 4.1 in 105 mm
 Shed Diameter (B2): 4.7 in 120 mm
 Shed Spacing (C): 2.0 in 51 mm
 Trunnion Bolt (F): 5/8 in - 11 bolt & lockwasher
 Dry Arc Distance: 22.3 in 567 mm
 Leakage Distance: 54.0 in 1,372 mm

Electricals Values

60 Hz dry Flashover:	224 kV	Min. Withstand	211 kV
60 Hz Wet Flashover:	203 kV	Min. Withstand	152 kV
Pos. Critical Impulse Flashover:	381 kV	Min. Withstand	328 kV
Neg. Critical Impulse Flashover:	472 kV	Min. Withstand	368 kV

Mechanical Values

Specified Tensile Load (STL):	5,000 lbs	22.2 kN
Max. Design Cant. Load (MDCL):	1,250 lbs	5.6 kN
Specified Cant. Load (SCL):	2,500 lbs	11.1 kN

This drawing contains confidential information that is the property of MacLean Power, L.L.C. ("MacLean"). Use of MacLean's confidential information without MacLean's express written consent is strictly prohibited and may expose you to legal liability. If you believe that you received this material in error, please destroy it or return it to "MacLean Power, L.L.C., 7801 Park Place Rd., York, South Carolina 29745, USA."

Notes:

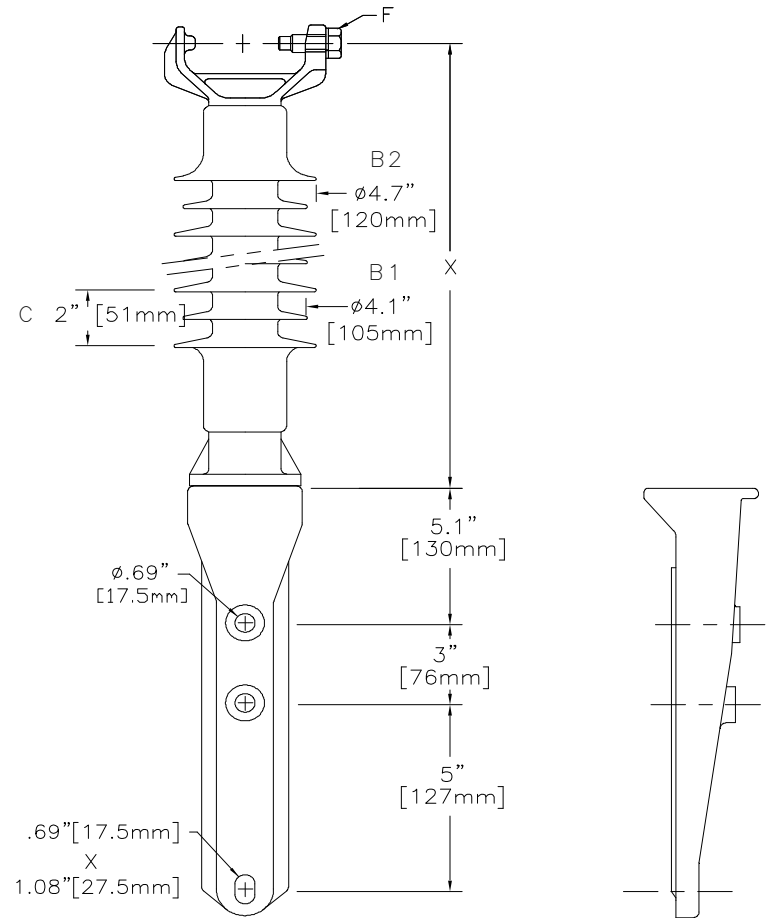

Dimension: inches [millimeters]

NOTE: Drawing not actual depiction of insulator appearance

Silicone Rubber Sheath & Sheds. Complies with applicable ANSI and IEC standards.

Prepared By: Stephen Lucci