

End Fittings

Tower End Fitting: Stud Base (P4 = 3/4" - 10) / 90 deg / Galv. Ductile Iron

Line End Fitting: Vertical Trunnion / Galv. Ductile Iron

Material

Mounting Angle: 90 deg
Number of Sheds: 5
Rod Diameter: 1.50 in
Weight Estimate: 7.1 lbs 3.2 kg

Dimensional Values

Section Length (X): 14.9 in 379 mm
Shed Diameter (B): 4.1 in 105 mm
Shed Spacing (C): 2.0 in 51 mm
Trunnion Bolt (F): 5/8 in - 11 bolt & lockwasher
Dry Arc Distance: 11.2 in 285 mm
Leakage Distance: 18.8 in 478 mm

Electricals Values

60 Hz dry Flashover:	122 kV	Min. Withstand	115 kV
60 Hz Wet Flashover:	103 kV	Min. Withstand	77 kV
Pos. Critical Impulse Flashover:	208 kV	Min. Withstand	179 kV
Neg. Critical Impulse Flashover:	271 kV	Min. Withstand	211 kV

Mechanical Values

Specified Tensile Load (STL):	5,000 lbs	22.2 kN
Max. Design Cant. Load (MDCL):	1,235 lbs	5.5 kN
Specified Cant. Load (SCL):	2,470 lbs	11.0 kN

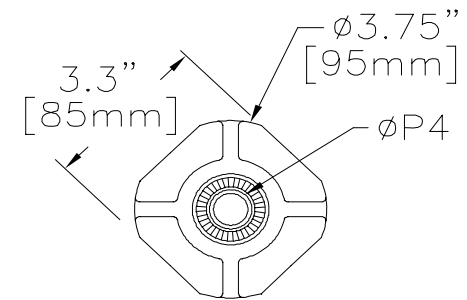
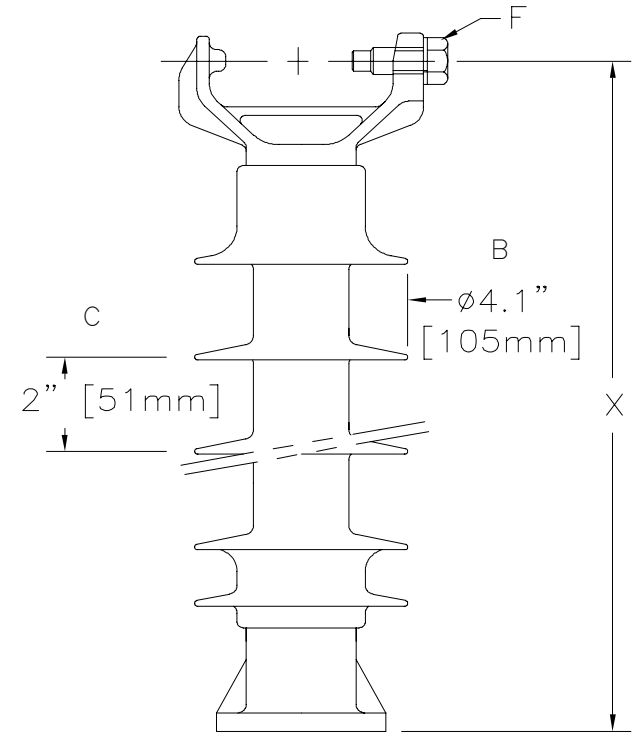

Dimension: inches [millimeters]

NOTE: Drawing not actual depiction of insulator appearance

Silicone Rubber Sheath & Sheds. Complies with applicable ANSI and IEC standards.

This drawing contains confidential information that is the property of MacLean Power, L.L.C. ("MacLean"). Use of MacLean's confidential information without MacLean's express written consent is strictly prohibited and may expose you to legal liability. If you believe that you received this material in error, please destroy it or return it to "MacLean Power, L.L.C., 7801 Park Place Rd., York, South Carolina 29745, USA."

Notes:

Prepared By: Stephen Lucci