

PAPER SIZE	DRAWING NUMBER	
B SIZE	GD-J24515	
REV	REVISION DATE	ECO
A	06-11-19	D9557

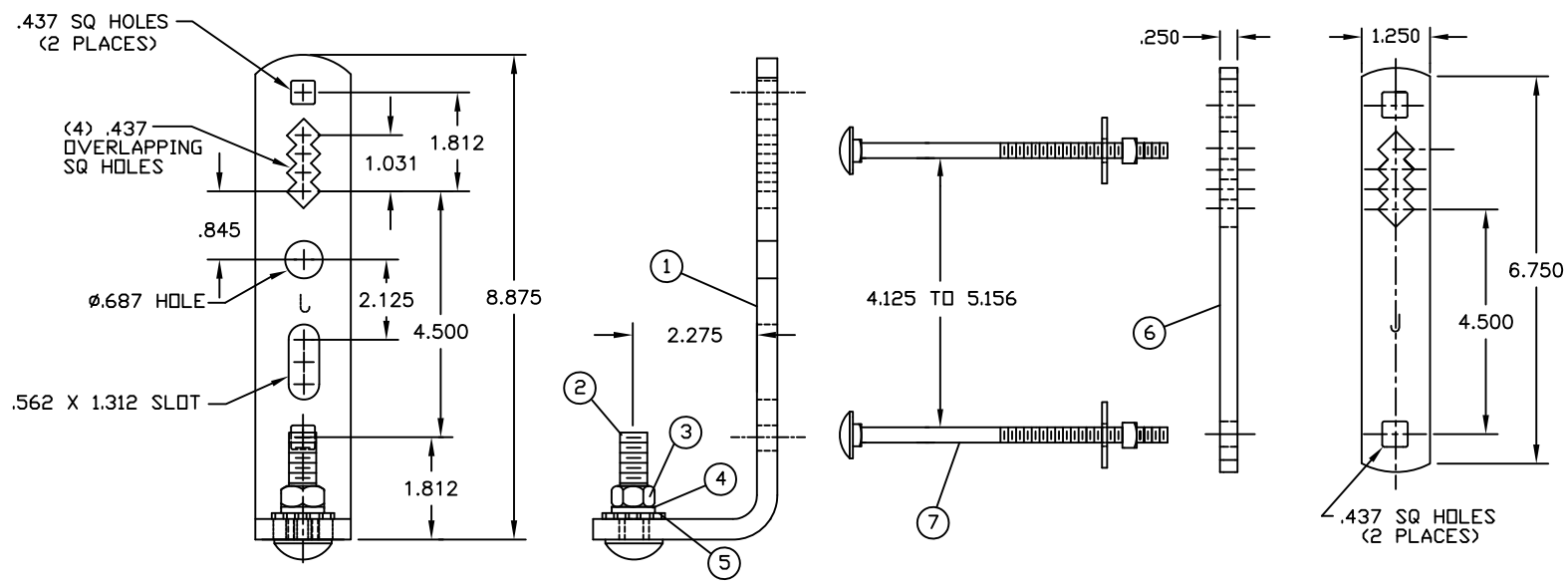

ITEM	QTY	DESCRIPTION
1	1	.375 X 1.750 ANGLE STRAP
2	1	.500 X 2.000 CARRIAGE BOLT
3	1	.500 REGULAR HEX NUT
4	1	.500 SPRING LOCKWASHER
5	1	.500 EXTERNAL TOOTH LOCKWASHER
6	1	.250 X 1.250 BACK STRAP
7	2	.375 X 6.000 CARRIAGE BOLT ASSY

- NOTES:**
- 1) MATERIAL: CARBON STEEL.
 - 2) ALL DIMENSIONS ARE REFERENCE AND ARE IN INCHES.
 - 3) FINISH: ALL ITEMS GALVANIZED.

This drawing contains confidential information that is the property of MacLean Power, L.L.C. ("MacLean"). Use of MacLean's confidential information without MacLean's express written consent is strictly prohibited and may expose you to legal liability. If you believe that you received this material in error, please destroy it or return it to "MacLean Power, L.L.C., 11411 Addison, Franklin Park, Illinois 60131, USA."

TOLERANCES UNLESS SPECIFIED
INCH
0.XX
0.XXX
ANGLE



DRAWN BY	ENGINEER	CHECKER	CATALOG #	SCALE	DESIGN DATE
MTT	RRL	MTT	J24515	NTS	08-04-11
DRAWING TITLE / DESCRIPTION					DRAWING NUMBER
BRACKET EQUIP					GD-J24515