

|            |            |                  |       |
|------------|------------|------------------|-------|
| PAPER SIZE |            | DRAWING NUMBER   |       |
| <b>B</b>   |            | <b>GD-J26716</b> |       |
| REV        | REVISED BY | REVISION DATE    | ECO # |
| A          | MTT        | 06-24-19         | D9557 |

TABLE 1: BILL OF MATERIALS

| ITEM NO. | DESCRIPTION          | QTY | MATERIAL                | ALTERNATE MATERIAL          |
|----------|----------------------|-----|-------------------------|-----------------------------|
| 1        | CLAMP BODY UPPER     | 1   | CAST ALUMINUM           | -                           |
| 2        | CLAMP BODY LOWER     | 1   | CAST ALUMINUM           | -                           |
| 3        | MACH BOLT 3/8 X4.000 | 1   | STAINLESS STEEL         | GALVANIZED HOT ROLLED STEEL |
| 4        | WASHER 3/8           | 1   | STAINLESS STEEL         | -                           |
| 5        | LOCKWASHER 3/8       | 1   | GALVANIZED SPRING STEEL | GALVANIZED HOT ROLLED STEEL |
| 6        | NUT HEX 3/8          | 1   | STAINLESS STEEL         | GALVANIZED HOT ROLLED STEEL |

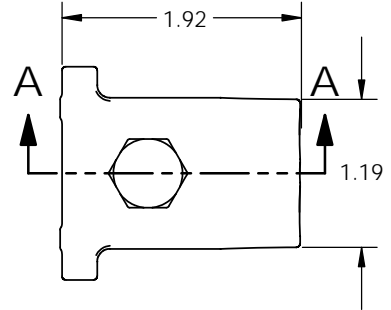
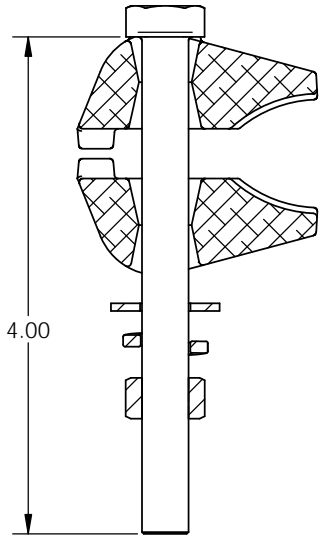

SECTION A-A

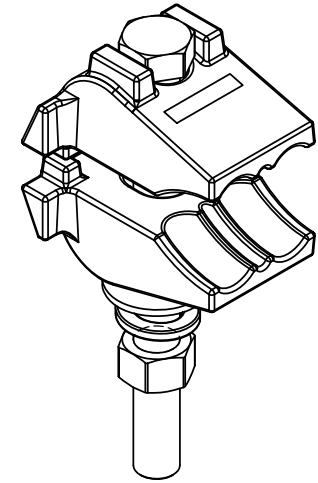
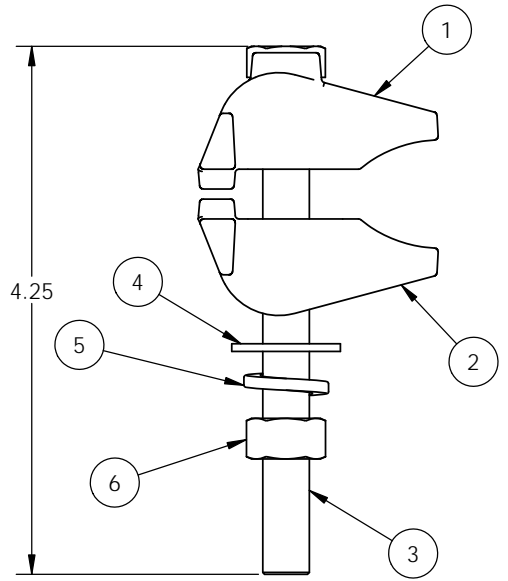

|          |                 |
|----------|-----------------|
| ROD TYPE | ROD SIZE        |
| TWIN EYE | 5/8", 3/4" & 1" |

CATALOG NUMBER J26716

USE OR REPRODUCTION OF THIS DRAWING FOR THE PURPOSE OF MANUFACTURING THIS ARTICLE OR ARTICLES SHOWN OR ANY OTHER PURPOSE IS STRICTLY PROHIBITED EXCEPT ON WRITTEN PERMISSION \*\*MACLEAN POWER SYSTEMS\*\*

UNLESS OTHERWISE SPECIFIED  
DIMENSIONS ARE IN:

**INCHES**

TOLERANCES ARE:

|        |          |
|--------|----------|
| XX     | +/- .XX  |
| .XXX   | +/- .XXX |
| X/XX   | +/- X/XX |
| ANGLES | +/- .XXX |



**MACLEAN  
POWER  
SYSTEMS**

RELIABLE POWER PRODUCTS  
11411 ADDISON STREET  
FRANKLIN PARK, IL 60131  
TEL: (847) 455-0014 FAX: (847) 455-0029

|   |  |   |  |
|---|--|---|--|
| DRAWING NUMBER:<br><b>GD-J26716</b>       |  | DO NOT SCALE DRAWING                            |  |
| SHEET NAME:<br>Sheet1                     |  | 1 OF 1  |  |
| DRAWING DESCRIPTION:<br>CLAMP GUY BONDING |  | CAD GENERATED DRAWING<br>DO NOT MANUALLY UPDATE |  |
| DESIGN DATE: 02/11/09                     |  | DRAWN BY: MTT                                   |  |
| ENGINEER: RRL                             |  | APPROVED:                                       |  |
| DRAWING SCALE: 1:1                        |  |   |  |