

## Installation and Operation

### Table of Contents

Section	Page	Section	Page
<b>Introduction</b>		<b>Installation</b>	
Qualified Persons .....	2	Mounting the Fuse Cutout .....	6
Read this Instruction Sheet .....	2	Installing the Fuse Link (Fuse Cutouts Without Arc-Shortening Rod) .....	7
Retain this Instruction Sheet .....	2	(Fuse Cutouts With Arc-Shortening Rod) .....	8
Proper Application .....	2	Installing and Closing the Fuse Tube .....	9
Warranty .....	3	Opening the FuseTube .....	10
<b>Safety Information</b>		<b>Operation</b>	
Understanding Safety-Alert Messages .....	4	Operation with Loadbuster® .....	11
Following Safety Instructions .....	4		
Replacement Instructions and Labels .....	4		
<b>Safety Precautions</b> .....	5		
<b>Inspection</b> .....	5		



♦ Also applicable on 26.4-kV through 34.5-kV systems for protection of single-phase-to-neutral circuits (lines or transformers) only, and grounded-wye connected capacitor banks.



**Qualified Persons**

**WARNING**

The equipment covered by this publication must be installed, operated, and maintained by qualified persons who are knowledgeable in the installation, operation, and maintenance of primary distribution fusing equipment along with associated hazards. A qualified person is one who is trained and competent in:

- The skills and techniques necessary to distinguish exposed live parts from non-live parts of electrical equipment.
- The skills and techniques necessary to determine the proper approach distances corresponding to the voltages to which the qualified person will be exposed.
- The proper use of the special precautionary techniques, personal protective equipment, insulating and shielding materials, and insulated tools for working on or near exposed energized parts of electrical equipment.

These instructions are intended only for such qualified persons. They are not intended to be a substitute for adequate training and experience in safety procedures for this type of equipment.

**Read this  
Instruction Sheet**

Thoroughly and carefully read this instruction sheet before installing or operating your MPS Type XS Fuse Cutout. The latest version is available online in PDF format at [www.maclepower.com](http://www.maclepower.com) under the "Technical References" tab.

**Retain this  
Instruction Sheet**

This instruction sheet should be available for reference wherever fuse cutouts are used. Retain this instruction sheet in a location where you can easily retrieve and refer to it.

**Proper Application**

**CAUTION**

Type XS Fuse Cutouts must only be used for specific fusing applications that are within the ratings of the model selected. Type XS fuse cutout ratings are listed on a ratings label attached to the unit.

**Understanding  
Safety-Alert Messages**

There are several types of safety-alert messages which may appear throughout this instruction sheet as well as on labels and tags attached to the Type XS Fuse Cutout. Familiarize yourself with these types of messages and the importance of the various signal words, as explained below.

<b>DANGER</b>
<p>“DANGER” identifies the most serious and immediate hazards which will likely result in serious personal injury or death if instructions, including recommended precautions, are not followed.</p>

<b>WARNING</b>
<p>“WARNING” identifies hazards or unsafe practices which can result in serious personal injury or death if instructions, including recommended precautions, are not followed.</p>

<b>CAUTION</b>
<p>“CAUTION” identifies hazards or unsafe practices which can result in minor personal injury or product or property damage if instructions, including recommended precautions, are not followed.</p>

<b>NOTICE</b>
<p>“NOTICE” identifies important procedures or requirements that, if not followed, can result in product or property damage if instructions are not followed.</p>

**Following Safety  
Instructions**

If you do not understand any portion of this instruction sheet and need assistance, contact your nearest MPS Sales Office or Authorized Distributor.

<b>NOTICE</b>	
<p>Thoroughly and carefully read this instruction sheet before operating your MPS Type XS Fuse Cutout.</p>	

**Replacement Instructions  
and Labels**

If you need additional copies of this instruction sheet, contact your nearest MPS Sales Office, Authorized Distributor, or Headquarters.

It is important that any missing, damaged, or faded labels on the equipment be replaced immediately. Replacement labels are available by contacting your nearest MPS Sales Office, Authorized Distributor, or Headquarters.

**DANGER**



**Type XS Fuse Cutouts operate at high voltage. Failure to observe the precautions below will result in serious personal injury or death.**

Some of these precautions may differ from your company's operating procedures and rules. Where a discrepancy exists, follow your company's operating procedures and rules.

1. **QUALIFIED PERSONS.** Access to Type XS Fuse Cutout must be restricted only to qualified persons. See "Qualified Persons" on page 2.
2. **SAFETY PROCEDURES.** Always follow safe operating procedures and rules.
3. **PERSONAL PROTECTIVE EQUIPMENT.** Always use suitable protective equipment such as rubber gloves, rubber mats, hard hats, safety glasses, and flash clothing in accordance with safe operating procedures and rules.
4. **SAFETY LABELS AND TAGS.** Do not remove or obscure any of the "DANGER," "WARNING," "CAUTION," or "NOTICE" labels and tags. Remove tags **ONLY** if instructed to do so.
5. **ENERGIZED COMPONENTS.** Always consider all parts live until de-energized, tested, and grounded.
6. **OPERATING TOOLS.** To close a Type XS Fuse Cutout, use a conventional insulated hookstick or S&C Universal Pole and Pole Extension fitted with an S&C Talon™ Handling Fitting or a distribution prong. To open the Type XS Fuse Cutout, use a Loadbuster®—The S&C Loadbreak Tool, attached to a conventional insulated hookstick or S&C Universal Pole.
7. **MAINTAINING PROPER CLEARANCE.** Always maintain proper clearance from energized components.

Examine the shipment for external evidence of damage as soon after receipt as possible, preferably before removal from the carrier's conveyance. Check the bill of lading to make sure that all shipping pallets and/or cartons are present.

If there is visible loss and/or damage:

1. Notify the delivering carrier immediately.
2. Ask for a carrier inspection.
3. Note condition of shipment on all copies of the delivery receipt.
4. File a claim with the carrier.

If concealed damage is discovered:

1. Notify the delivering carrier within 15 days of receipt of shipment.
2. Ask for a carrier inspection.
3. File a claim with the carrier.

Also notify MacLean Power Systems in all instance of loss and/or damage.

## Mounting the Fuse Cutout

### CAUTION

To prevent damage during transport and handling, keep the Type XS Fuse Cutout in its carton until you are ready to install it. Failure to do so can result in improper operation, arcing, or electric shock.

**Step 1** Attach the fuse cutout to a suitable mounting bracket as illustrated in Figure 1. NOTE: A mounting bracket, suitable for cross-arm, pole, or wall mounting, is furnished only if so specified on order by adding suffix “-B” or “-C” to catalog number of fuse cutout.

**Step 2** Mount the fuse cutout on the mounting bracket, as shown in Figure 1, with the carriage bolt nut snug but loose enough for pivot adjustment. Note the placement of the external-tooth lockwasher between the fuse cutout center insert and the mounting bracket. See Figure 1.

**Step 3** Pivot the fuse cutout to a position that will provide maximum ease of operation and securely tighten the carriage bolt nut.

**Step 4** Make electrical connections. Be sure to wire-brush any aluminum conductors and apply a coating of oxidation inhibitor before inserting such conductors in the fuse cutout connectors. Tighten connector hardware to 20 ft. lbs.

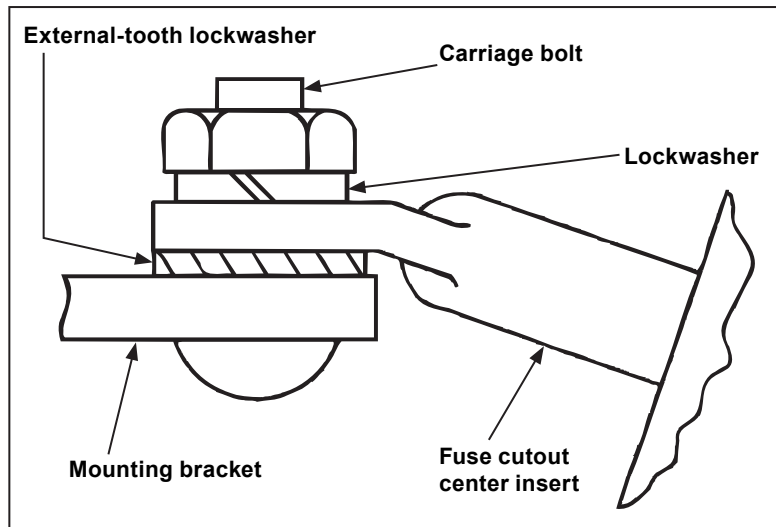

Figure 1. Detail of attachment of fuse cutout to mounting bracket.

## Installing the Fuse Link (Fuse Cutouts Without Arc-Shortening Rod)

**Step 1** Hand tighten the contact button on the fuse link and carefully straighten the cable.

**Step 2** Remove the cap from the upper ferrule of the fuse-tube assembly. Slide the fuse link, cable end first, into the top of the fuse-tube assembly and retrieve it at the lower end.

**Step 3** Replace the fuse-tube cap on the fuse-tube upper ferrule and tighten the cap securely using a wrench. Loosen the cable clamping nut on the trunnion. See Figure 2a.

**Step 4** Rotate the flipper fully about its pivot until it reaches its stop (firm resistance is felt). See Figure 2a.

Hold the flipper in this position, and feed the cable through the flipper channel and around the threaded stud in a clockwise direction as shown in Figure 2b.

Maintain tension on the fuse-link cable and firmly tighten the cable clamping nut, using a wrench. Do not overtighten the cable clamping nut.

**Step 5** Clip excess cable to within 1/2 inch (13 mm) of the nut.

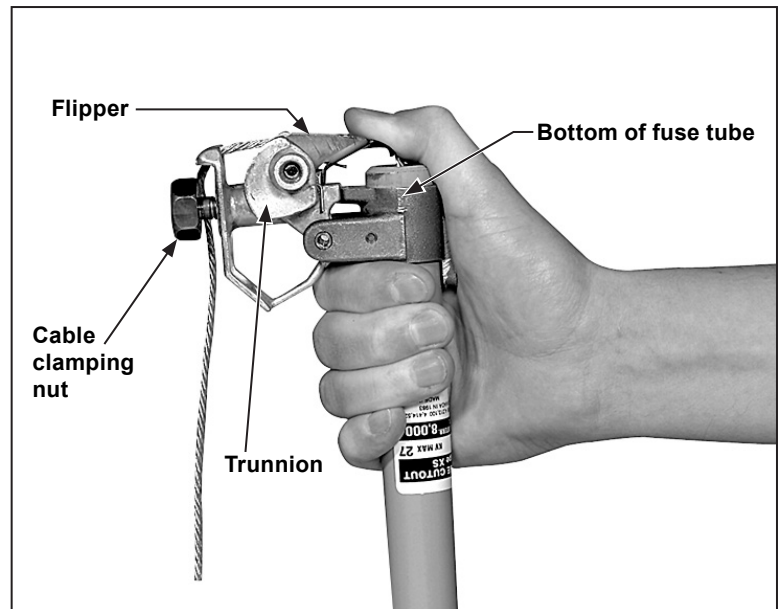

Figure 2a. Flipper fully pivoted.

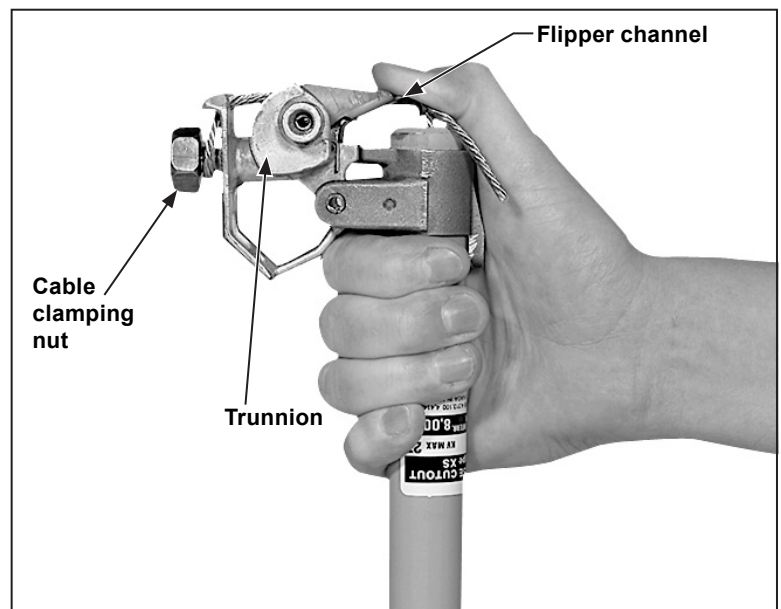

Figure 2b. Cable under tension around nut.

### **Installing the Fuse Link (Fuse Cutouts with Arc-Shortening Rod)**

Fuse cutouts having an arc-shortening rod require the use of removable buttonhead fuse links.

**Step 1** Remove and discard the contact button (and washer, for fuse links so equipped) and then carefully straighten the cable.

**Step 2** Unscrew the cap on the upper ferrule of the fuse-tube assembly and retract the arc-shortening rod (attached to the cap).

**Step 3**

#### **CAUTION**

Do not use a standard cap in place of a cap with an arc-shortening rod. Use of the arc-shortening rod is required to achieve the full interrupting rating.

Screw the arc-shortening rod onto the fuse link and hand tighten. Then slide this assembly, cable first, into the top of the fuse tube and retrieve the cable at the lower end. Continue with Step 3 of the preceding section.



## Installing and Closing the Fuse Tube

Only qualified persons should operate, inspect, or maintain a fuse cutout.

Such qualified persons should wear protective equipment such as rubber gloves, hard hat, . . . safety glasses, flash-clothes, etc., in accordance with established safety practices, and be trained in their proper care.

### WARNING

Hot gases and fuse link particles can be expelled at high velocity during interruption. When closing a fuse cutout, all personnel should be positioned well clear of its exhaust.

**Step 1** After installing the fuse link as described in the foregoing sections, insert the prong of a hookstick into the opening under the trunnion casting band. Or, as an alternate, insert the prong in the keyhole opening in the trunnion casting band.

**Step 2** Guide the fuse tube into the fuse cutout hinge as shown in Figure 3 and disengage the hookstick.

**Step 3** Insert the prong of the hookstick in the pull ring on the upper ferrule of the fuse tube and swing the fuse tube to within approximately 45° of the fully closed position. Then, while looking away from the fuse cutout, drive the fuse tube to the closed position using a vigorous thrust. Carefully disengage the hookstick taking care to avoid opening the fuse tube.

### DANGER

MPS Type XS Fuse Cutouts are designed to protect equipment. A fuse cutout cannot protect personnel from injury or electrocution if contact is made with energized circuits or hardware.

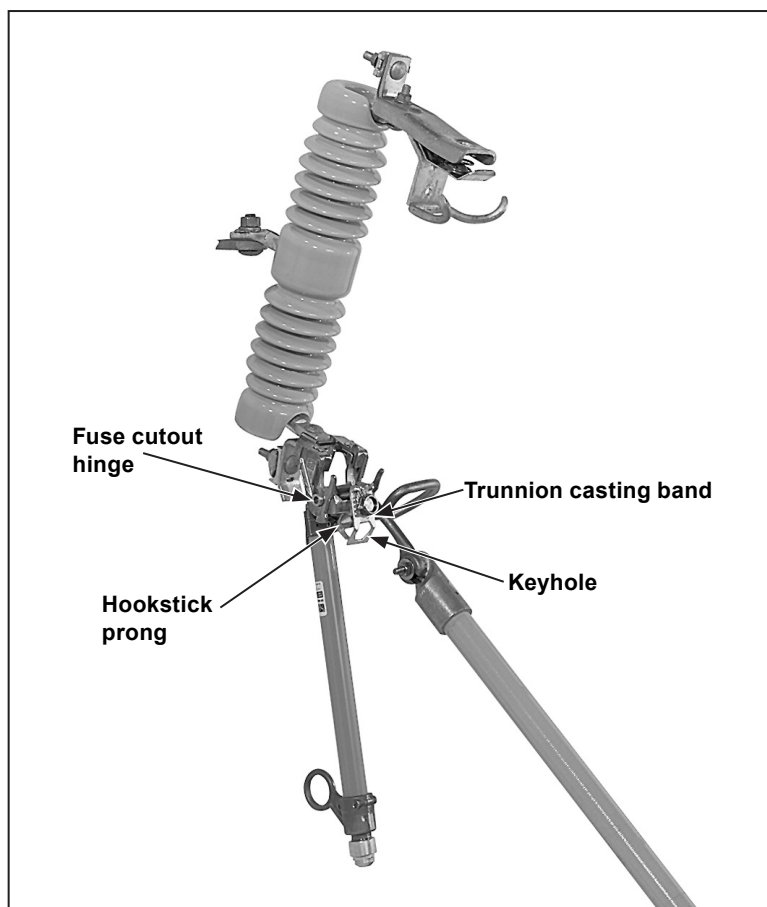

Figure 3. Installing the fuse tube.

## Opening the Fuse Tube

### **WARNING**

Do not attempt to open MPS Type XS Fuse Cutouts to interrupt load current, without the use of a loadbreak tool such as S&C's Loadbuster®. An arc started by opening a fuse cutout under load without a loadbreak tool could cause injury or damage to equipment.

S&C's Loadbuster is ideally suited for use in opening the fuse tube of MPS Type XS Fuse Cutouts (or other fuse cutouts and disconnects designed for use with Loadbuster). Loadbuster is S&C's unique method of providing low-cost, positive, and convenient live-switching capability for such devices. Instructions for use of Loadbuster with MPS Type XS Fuse Cutouts are shown below.

Following an opening operation using Loadbuster, the fuse tube can be lifted out of the fuse cutout hinge using the prong of a hookstick. See Figure 3 on page 9.

### **IMPORTANT**

A fuse tube should not be left in the open position for an extended period of time, since water can damage the tube lining.

## Operating with Loadbuster

Check for proper resetting of the Loadbuster by extending the tool about three inches by hand. Throughout this travel, an increasing spring resistance should be felt.

**Step 1** Reach across in front of the fuse cutout with Loadbuster and hook the anchor, located at the top of Loadbuster, over the attachment hook on the far side of the fuse cutout. See Figure 4.

**Step 2** Swing Loadbuster toward the fuse tube and pass the Loadbuster pull-ring hook through the pull ring on the fuse tube. The pull-ring latch will deflect and upon complete entry of the pull ring, will spring back, locking Loadbuster to the pull ring. Loadbuster is now connected across the upper contact of the fuse cutout. See Figure 4.

**Step 3** To open the circuit, operate Loadbuster with a firm, steady pull until it is extended to its maximum length. See Figure 5. Avoid jerking and hesitation. The resetting latch will keep it open. Generally, there will be no indication of circuit interruption, but commutation arcing may be noted at the pull-ring hook and at the anchor, particularly when interrupting load currents approaching the rating of the tool. The only sound will be that of Loadbuster tripping.

**Step 4** To detach Loadbuster after circuit interruption, first raise it slightly and disengage the anchor from the attachment hook.

### WARNING

When Loadbuster is raised the open gap distance is reduced. Careless manipulation could decrease the open gap to the point where flashover will occur.

Next, bring the fuse tube toward its fully open position as illustrated in Figure 6. Then remove Loadbuster from the pull ring by turning the pole. This will deflect the pull-ring latch to release the pull ring. Because the fuse tube will drop fully open by gravity, it may be preferred to remove Loadbuster by “rolling” it off both the attachment hook and pull ring at the same time merely by twisting the pole after Loadbuster has been tripped and fully extended. To perform this operation easily and smoothly, always roll Loadbuster so that it rotates in an upward direction.

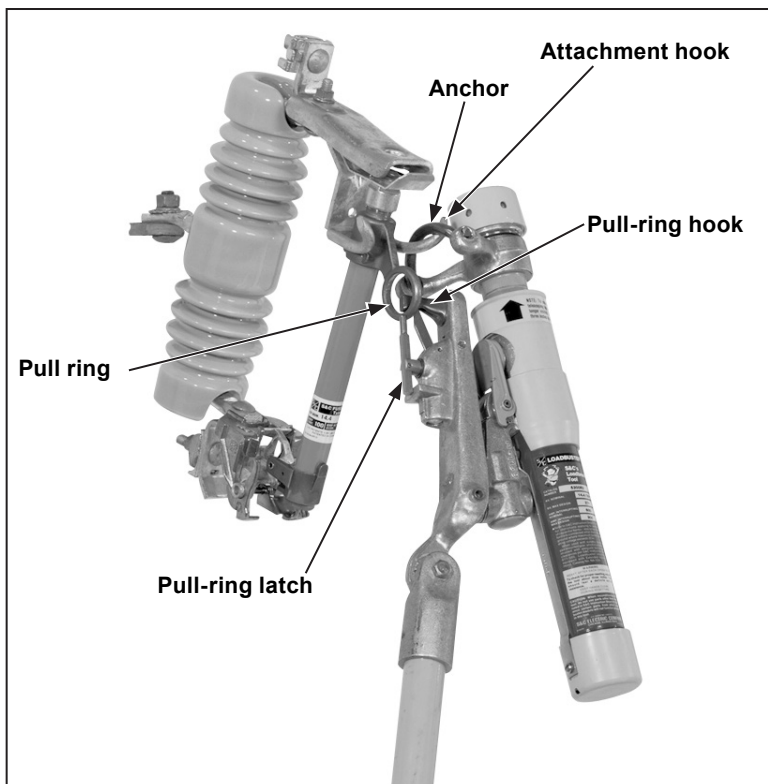

Figure 4. Loadbuster connected to MPS Type XS Fuse Cutout, Outdoor Distribution.

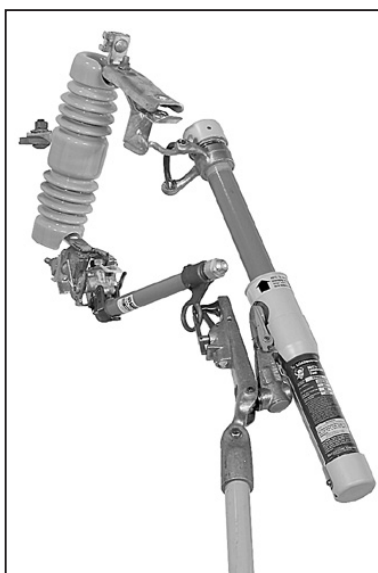

Figure 5. Loadbuster in tripped position.

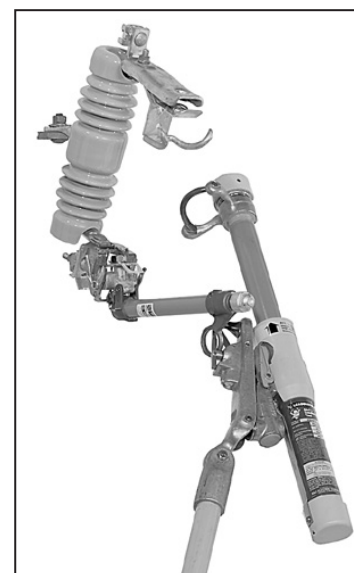

Figure 6. Detaching Loadbuster from fuse cutout.

**Step 5** To reset Loadbuster for the next operation, hold as shown in Figure 7. Extend the tool slightly and lift the resetting latch with the thumb. With the latch up, telescope the tool completely so the trigger can reset itself. Check for proper resetting by extending the tool about three inches. Throughout this travel an increasing spring resistance should be felt.

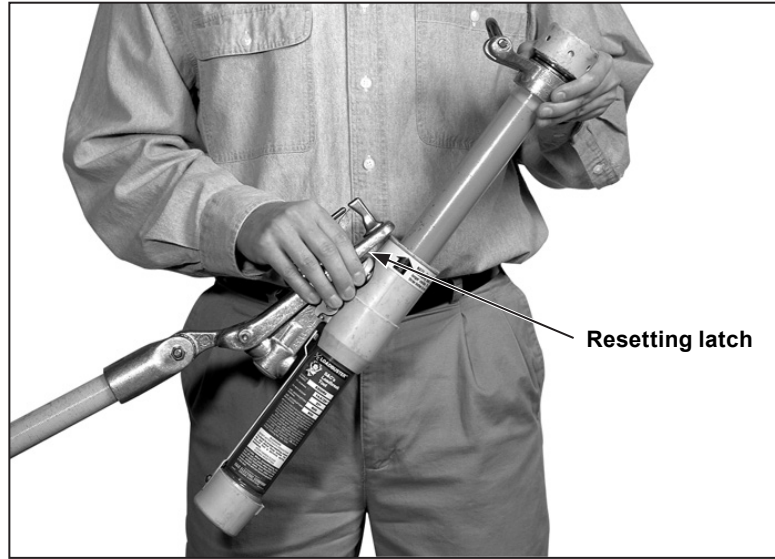

Figure 7. Resetting Loadbuster.