

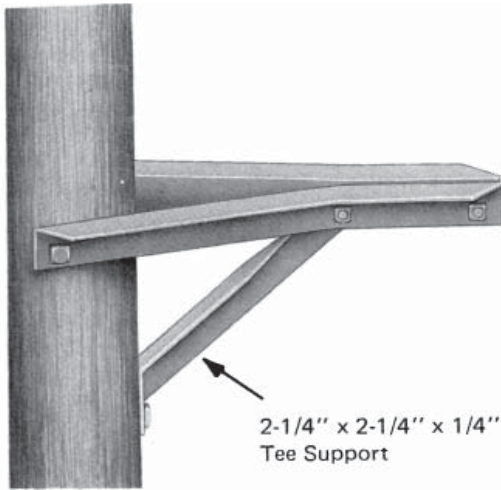

Brackets



Cable Extension

The cable extension bracket supports a telephone cable at a distance from the pole.

Features

- Messenger cable is held by a standard J1096 suspension clamp which is bolted against the underside of the two angles by a 5/8" machine bolt which is fitted between the legs of the two angles and can be adjusted for proper extension from the pole
- Mounts to pole with a 5/8" or 3/4" machine bolt at upper position and two 1/2" lag screw bolts at the lower
- All mounting bolts, lag screws and suspension clamps must be ordered separately

Material

Steel hot dip galvanized

Catalog Number	Angle Size	Extension from Center of Pole (in)	Weight /100 (lbs)
J7920	3 x 2 1/2 x 5/16	17 1/2 - 26	2900
J7921	3 1/2 x 2 1/2 x 5/16	26 1/2 - 44 1/2	6000

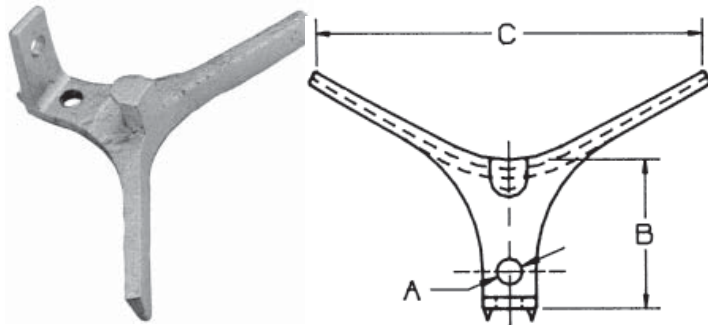

Conduit Mounting Standoff

Features

- Brackets will accommodate 1-3 conduits up to 6" diameter each
- Conduit is secured by banding to post on bracket
- Mounts to pole with 5/8" machine bolt

Material

Steel hot dip galvanized

Catalog Number	A	B	C	Weight /100 (lbs)
CRB396	11/16	4	10 1/2	270