

ITEM NO.	PART NUMBER	DESCRIPTION	QTY.
1	P61342	HEAVY DUTY TANGENT BASE DRILLED & TAPPED	1
2	P68244	4" x 4" SQUARE WASHER W/ ϕ 13/16" HOLE	2
3	F338983	3/4" LOCKWASHER	2
4	P55909	3/4" - 10 x 5" GRADE 5 HEX HEAD BOLT	2
5	P23050	3/4 X 3.75 SLEEVE	2
6	P90008W	PW FOAMED TUBE	1

PAPER SIZE		DRAWING NUMBER	
B		3003-014	
REVISIONS			
REV.	ECO BY	ECO DATE	ECO NUMBER
A	TJK	9/25/13	00519

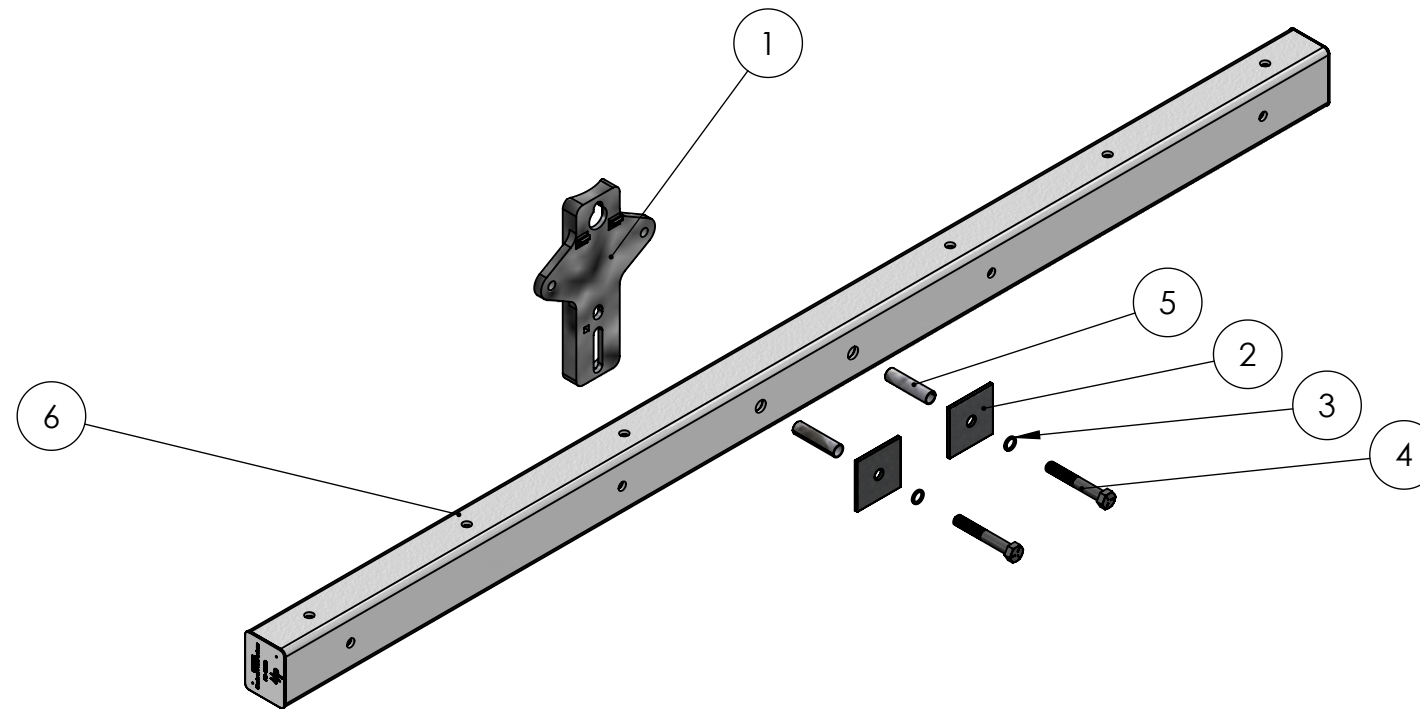

CATALOG NUMBER: PW08ST004		CUSTOMER NUMBER: N/A		PART NUMBER: F490156		DRAWING NUMBER: 3003-014		DO NOT SCALE DRAWING	
PHYSICAL PROPERTIES				UNLESS OTHERWISE SPECIFIED DIMENSIONS ARE IN: INCHES		SHEET: 1 OF 2		CAD GENERATED DRAWING DO NOT MANUALLY UPDATE	
				TOLERANCES ARE:		DRAWING DESCRIPTION: PW TANGENT CROSSARM		DESIGN DATE: 8/10/07	
MATERIAL: FIBERGLASS		APPROX. WEIGHT : 45 LBS		.XX +/- .03		DRAWN BY: TJK		ENGINEER: tkrohn	
VOLUME: IN3		X/XX +/- 1/32		X/XX +/- 1/32		APPROVED: 09/30/13		APPROVED: 09/30/13	
		ANGLES +/- 1°		7801 PARK PLACE RD. YORK, SC. 29745		PRODUCT LINE: CROSSARMS		SCALE: 1:12.5	
		TEL. (803) 628-2100		FAX: (803) 628-2139					

THIS DRAWING CONTAINS CONFIDENTIAL INFORMATION THAT IS THE PROPERTY OF MACLEAN POWER, L.L.C. ("MACLEAN"). USE OF MACLEAN'S CONFIDENTIAL INFORMATION WITHOUT MACLEAN'S EXPRESS WRITTEN CONSENT IS STRICTLY PROHIBITED AND MAY EXPOSE YOU TO LEGAL LIABILITY. IF YOU BELIEVE THAT YOU RECEIVED THIS MATERIAL IN ERROR, PLEASE DESTROY IT OR RETURN IT TO "MACLEAN POWER, L.L.C., 7801 PARK PLACE RD., YORK, SOUTH CAROLINA 29745, USA."

PAPER SIZE	DRAWING NUMBER
B	3003-014

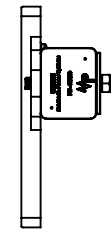
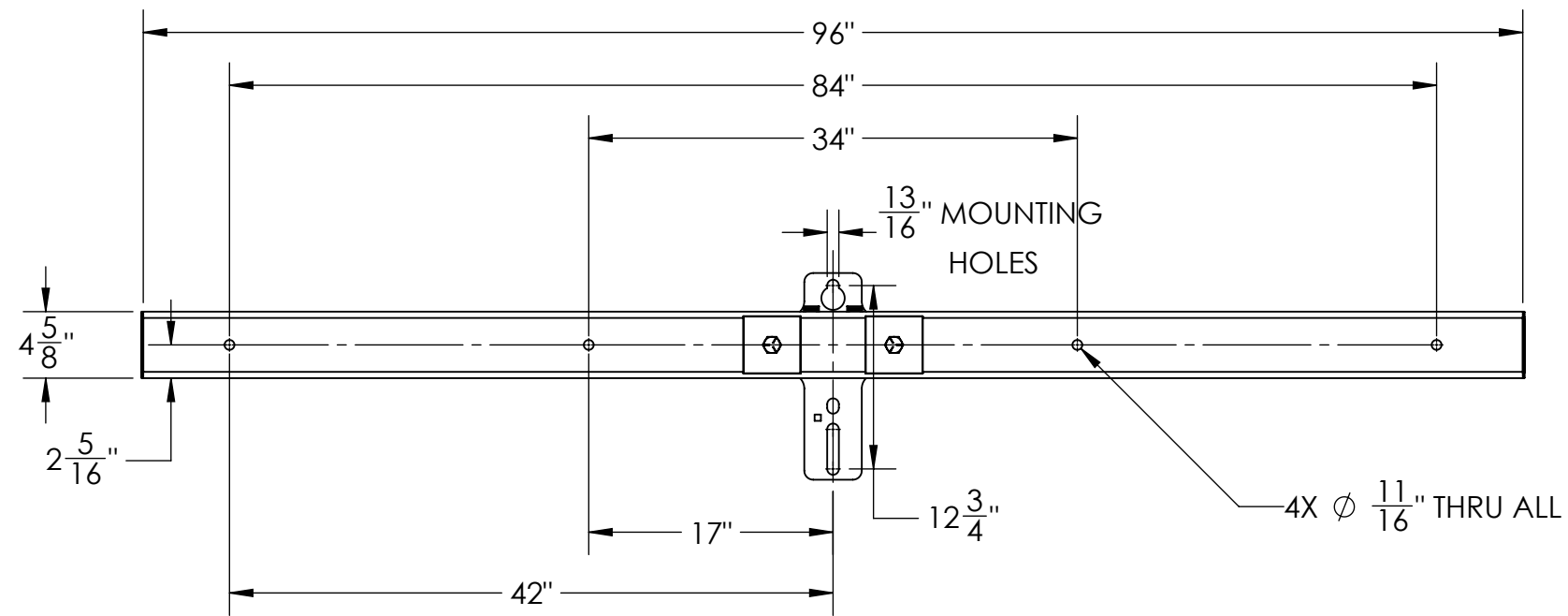
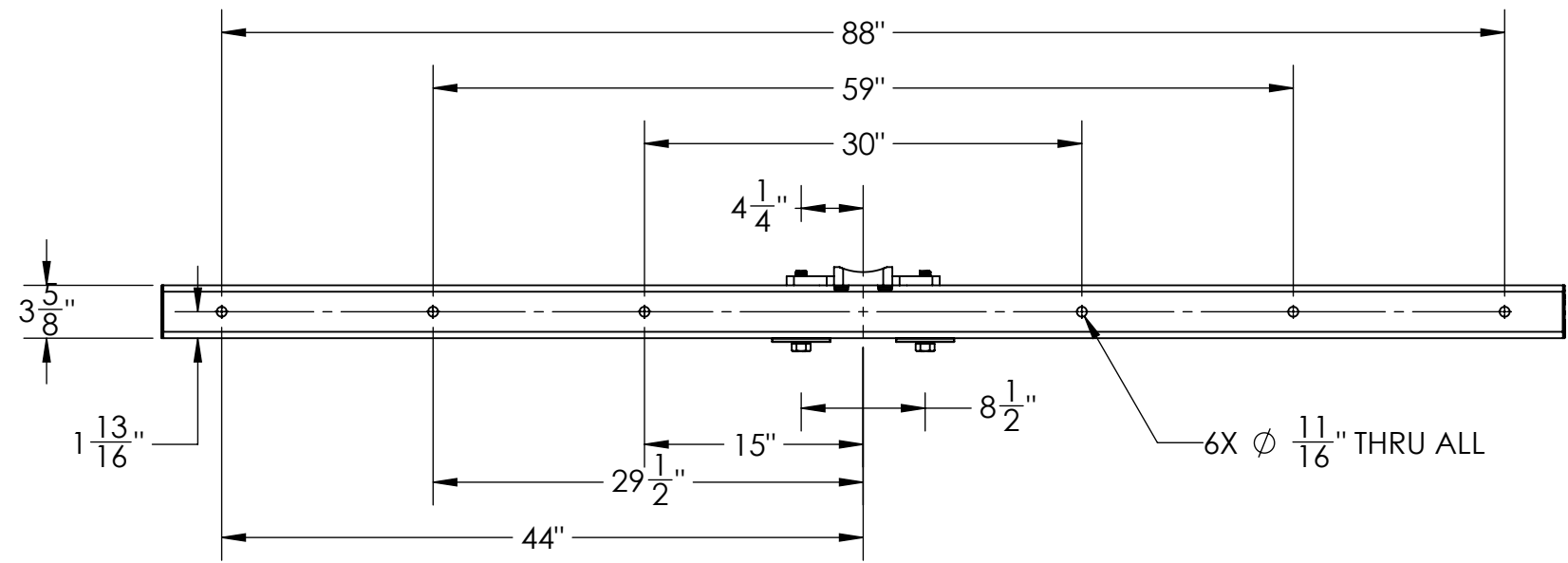

CATALOG NUMBER: PW08ST004		CUSTOMER NUMBER: N/A		PART NUMBER: F490156		DRAWING NUMBER: 3003-014		DO NOT SCALE DRAWING	
PHYSICAL PROPERTIES				UNLESS OTHERWISE SPECIFIED DIMENSIONS ARE IN: INCHES		SHEET: 2 OF 2		CAD GENERATED DRAWING DO NOT MANUALLY UPDATE	
				TOLERANCES ARE:		DRAWING DESCRIPTION: PW TANGENT CROSSARM		DESIGN DATE: 8/10/07	
MATERIAL: FIBERGLASS		APPROX. WEIGHT : 45 LBS		.XX +/- .03		.XXX +/- .015		DRAWN BY: TJK	
VOLUME: IN3				X/XX +/- 1/32		X/XX +/- 1/32		ENGINEER: tkrohn	
				ANGLES +/- 1°		TEL. (803) 628-2100 FAX: (803) 628-2139		APPROVED: 09/30/13	
						7801 PARK PLACE RD. YORK, SC. 29745		PRODUCT LINE: CROSSARMS	
								SCALE: 1:12.5	

THIS DRAWING CONTAINS CONFIDENTIAL INFORMATION THAT IS THE PROPERTY OF MACLEAN POWER, L.L.C. ("MACLEAN"). USE OF MACLEAN'S CONFIDENTIAL INFORMATION WITHOUT MACLEAN'S EXPRESS WRITTEN CONSENT IS STRICTLY PROHIBITED AND MAY EXPOSE YOU TO LEGAL LIABILITY. IF YOU BELIEVE THAT YOU RECEIVED THIS MATERIAL IN ERROR, PLEASE DESTROY IT OR RETURN IT TO "MACLEAN POWER, L.L.C., 7801 PARK PLACE RD., YORK, SOUTH CAROLINA 29745, USA."