

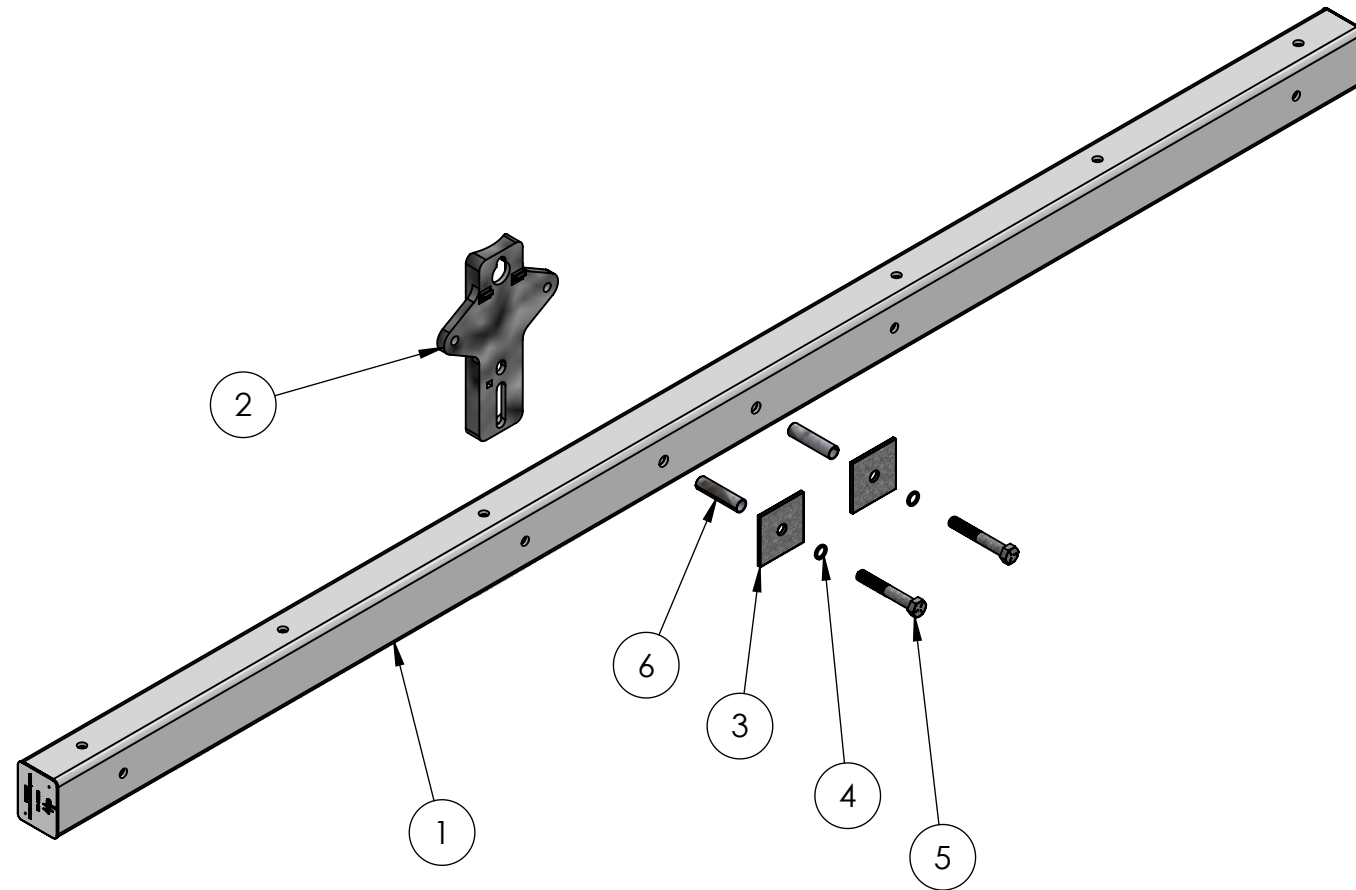

ITEM NO.	PART NUMBER	DESCRIPTION	QTY.
1	P90010W	PW FOAMED TUBE	1
2	P61342	HEAVY DUTY TANGENT BASE DRILLED & TAPPED	1
3	P68244	4" x 4" SQUARE WASHER W/ $\phi$ 13/16" HOLE	2
4	F338983	3/4" LOCKWASHER	2
5	P55909	3/4" - 10 x 5" GRADE 5 HEX HEAD BOLT	2
6	P23050	3/4" ID x 3 3/4" LONG SPACER TUBES	2

PAPER SIZE		DRAWING NUMBER	
<b>B</b>		<b>3003-055</b>	
REVISIONS			
REV.	ECO BY	ECO DATE	ECO NUMBER
A	MHK	06/25/14	01066



THIS DRAWING CONTAINS CONFIDENTIAL INFORMATION THAT IS THE PROPERTY OF MACLEAN POWER, L.L.C. ("MACLEAN"). USE OF MACLEAN'S CONFIDENTIAL INFORMATION WITHOUT MACLEAN'S EXPRESS WRITTEN CONSENT IS STRICTLY PROHIBITED AND MAY EXPOSE YOU TO LEGAL LIABILITY. IF YOU BELIEVE THAT YOU RECEIVED THIS MATERIAL IN ERROR, PLEASE DESTROY IT OR RETURN IT TO "MACLEAN POWER, L.L.C., 7801 PARK PLACE RD., YORK, SOUTH CAROLINA 29745, USA."

CATALOG NUMBER: <b>PW10ST005</b>		CUSTOMER NUMBER:		PART NUMBER: <b>N/A</b>		DRAWING NUMBER: <b>3003-055</b>		DO NOT SCALE DRAWING	
PHYSICAL PROPERTIES				UNLESS OTHERWISE SPECIFIED DIMENSIONS ARE IN: <b>INCHES</b>		SHEET: <b>1 OF 2</b>		CAD GENERATED DRAWING DO NOT MANUALLY UPDATE	
				TOLERANCES ARE:		DRAWING DESCRIPTION: <b>PW TANGENT CROSSARM</b>		DESIGN DATE: <b>06/25/14</b>	
MATERIAL: <b>FIBERGLASS</b>		.XX <b>+/- .03</b>		 <b>MACLEAN POWER SYSTEMS</b> 7801 PARK PLACE RD. YORK, SC. 29745 TEL. (803) 628-2100 FAX: (803) 628-2139		DRAWN BY: <b>MHK</b>		ENGINEER: <b>mkadel</b>	
APPROX. WEIGHT : <b>48 LBS</b>		.XXX <b>+/- .015</b>				APPROVED: <b>06/26/14</b>			
VOLUME: <b>IN3</b>		X/XX <b>+/- 1/32</b>				PRODUCT LINE: <b>CROSSARMS</b>			
		ANGLES <b>+/- 1°</b>				SCALE: <b>1:12.5</b>			

PAPER SIZE	DRAWING NUMBER
<b>B</b>	<b>3003-055</b>

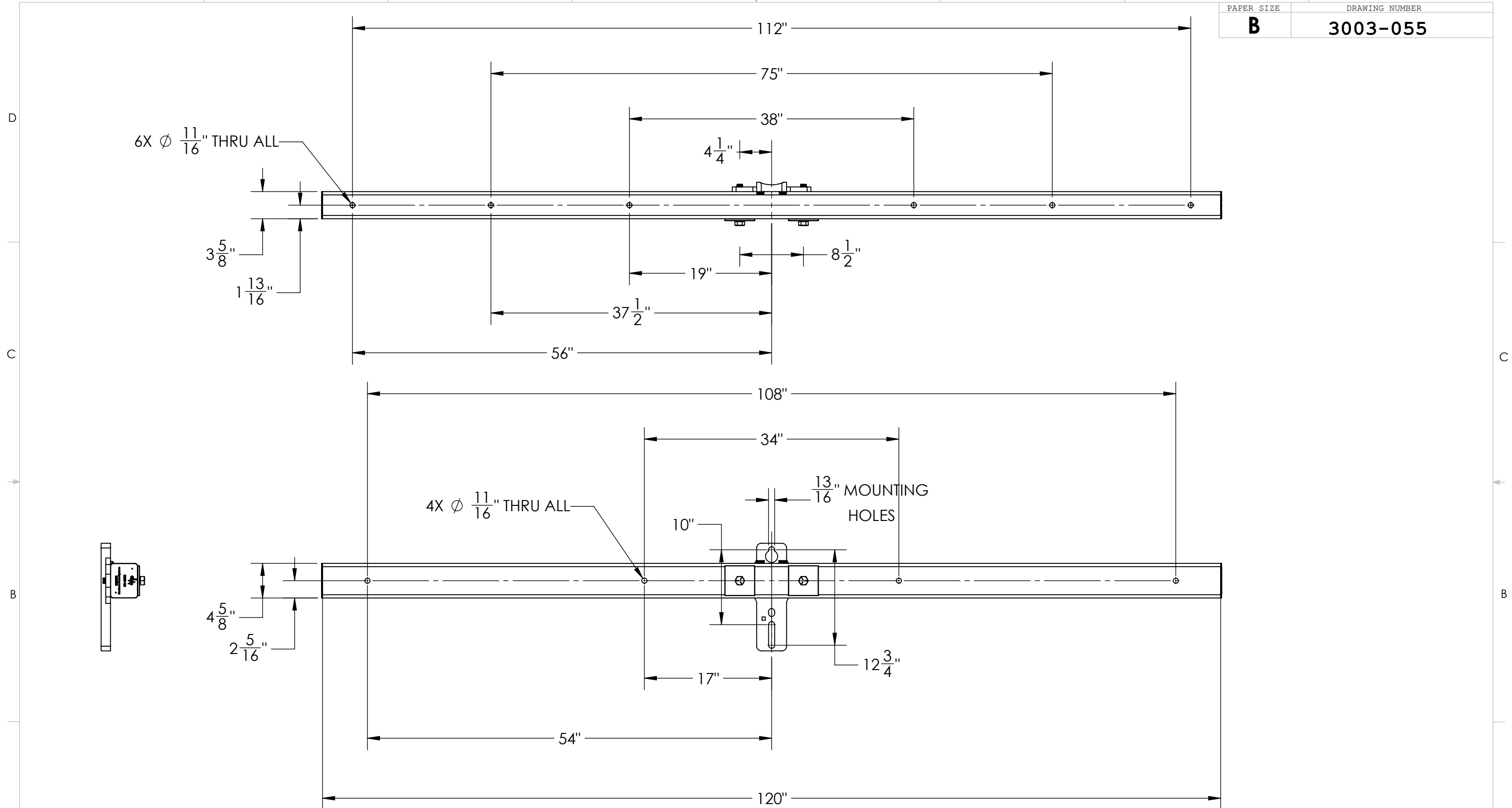

CATALOG NUMBER: <b>PW10ST005</b>	CUSTOMER NUMBER:	PART NUMBER: <b>N/A</b>	DRAWING NUMBER: <b>3003-055</b>	DO NOT SCALE DRAWING
<b>PHYSICAL PROPERTIES</b>	UNLESS OTHERWISE SPECIFIED DIMENSIONS ARE IN: <b>INCHES</b>		SHEET: <b>2 OF 2</b>	CAD GENERATED DRAWING DO NOT MANUALLY UPDATE
	TOLERANCES ARE:		DRAWING DESCRIPTION: <b>PW TANGENT CROSSARM</b>	DESIGN DATE: <b>06/25/14</b>
	MATERIAL: <b>FIBERGLASS</b>	.XX <b>+/- .03</b>	 <b>MACLEAN POWER SYSTEMS</b> 7801 PARK PLACE RD. YORK, SC. 29745	DRAWN BY: <b>MHK</b>
	APPROX. WEIGHT : <b>48 LBS</b>	.XXX <b>+/- .015</b>		ENGINEER: <b>mkadel</b>
VOLUME: <b>IN3</b>	X/XX <b>+/- 1/32</b>	TEL. (803) 628-2100 FAX: (803) 628-2139	APPROVED: <b>06/26/14</b>	SCALE: <b>1:12.5</b>
	ANGLES <b>+/- 1°</b>		PRODUCT LINE: <b>CROSSARMS</b>	

THIS DRAWING CONTAINS CONFIDENTIAL INFORMATION THAT IS THE PROPERTY OF MACLEAN POWER, L.L.C. ("MACLEAN"). USE OF MACLEAN'S CONFIDENTIAL INFORMATION WITHOUT MACLEAN'S EXPRESS WRITTEN CONSENT IS STRICTLY PROHIBITED AND MAY EXPOSE YOU TO LEGAL LIABILITY. IF YOU BELIEVE THAT YOU RECEIVED THIS MATERIAL IN ERROR, PLEASE DESTROY IT OR RETURN IT TO "MACLEAN POWER, L.L.C., 7801 PARK PLACE RD., YORK, SOUTH CAROLINA 29745, USA."