

PAPER SIZE		CATALOG NUMBER	
<b>B</b>		<b>AVC-3</b>	
REV	REVISED BY	REVISION DATE	ECO #
C	AR	11-17-17	D8502

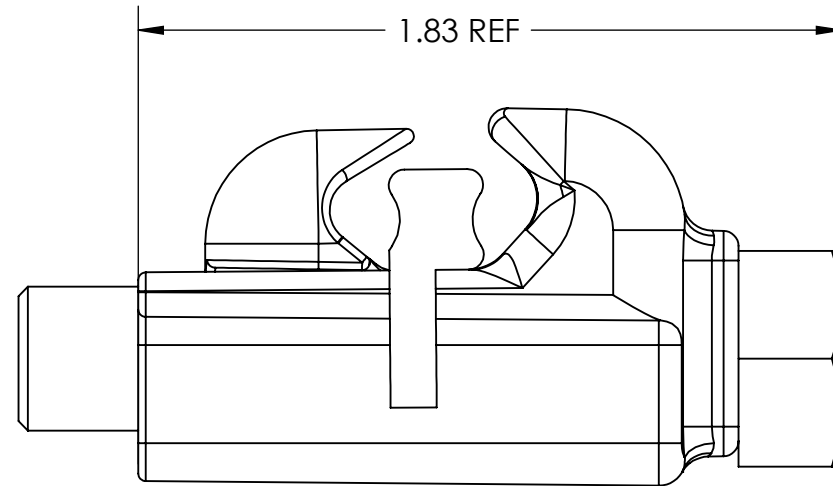

ITEM #	DESCRIPTION	MATERIAL	QUANTITY
1	BODY AVC-3	ALUMINUM ALLOY	1
2	JAW AVC-3	ALUMINUM ALLOY	1
3	BOLT HEX 3/8 x 1.875	STAINLESS STEEL	1
4	SPACER AVC-3	ALUMINUM	1

WIRE RANGE	
Main ACSR	#4 - #6
Main AL	8 SOL - 2 SOL
TAP ACSR	#4 - #6
TAP AL-CU	8 SOL - 2 SOL

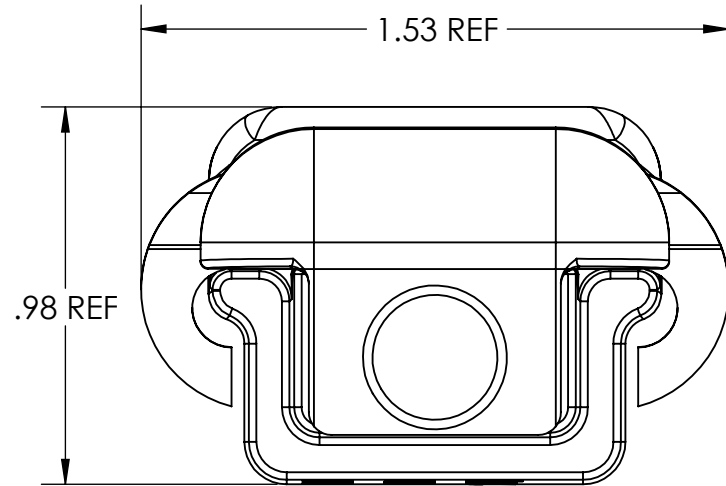
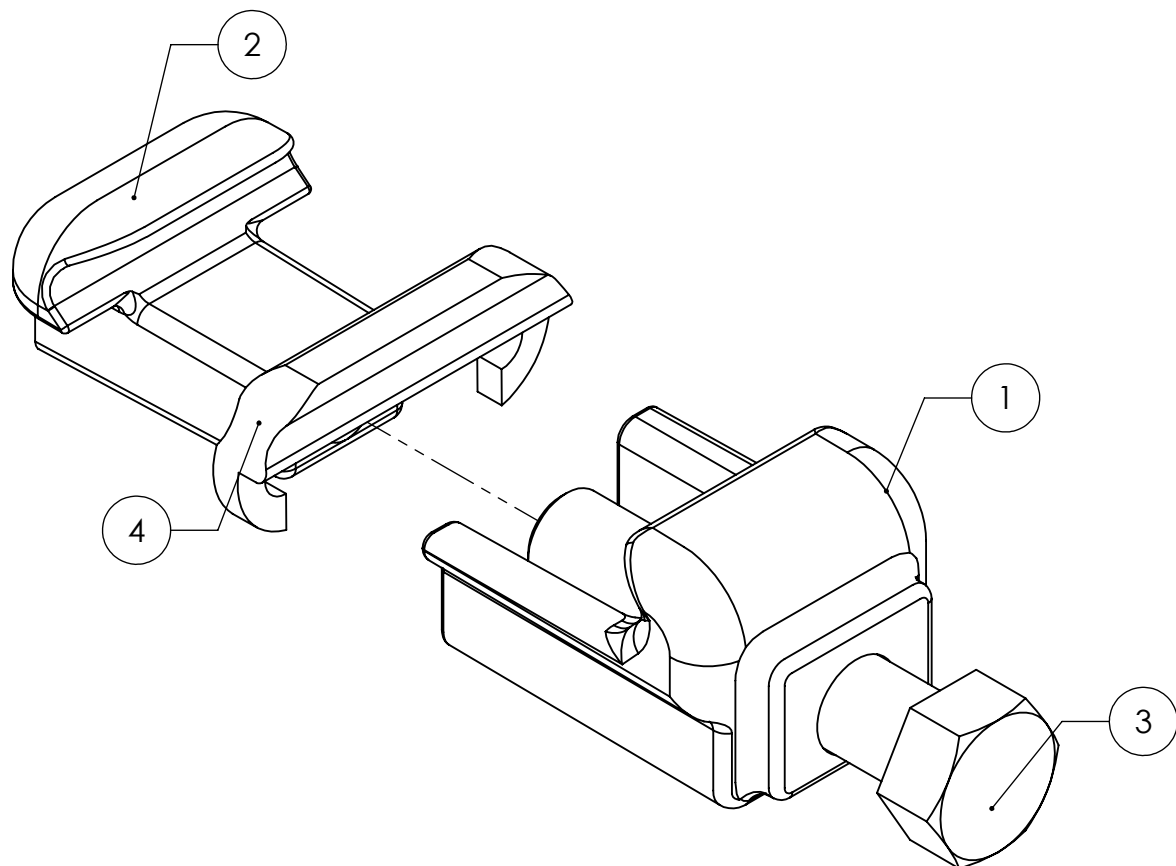
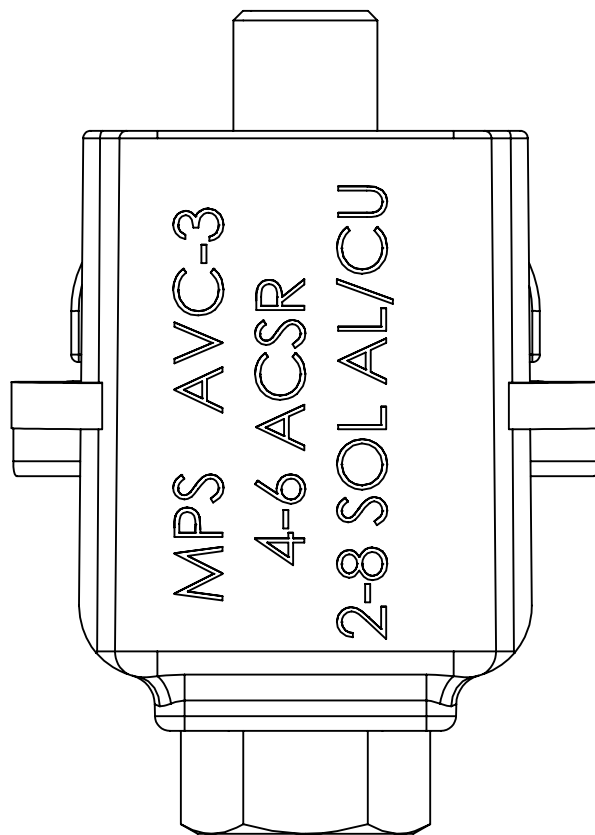

**Notes:**  
 All dimensions are in inches.  
 All dimensions are reference.  
 Standard pack is 250.  
 Recommended install torque: 15FT-LBS.  
 Hex bolt is compatible with standard 9/16" socket.  
 Oxide inhibitor is applied to all wire groove surfaces.  
 Plastic snap on cover for this part is CAVC2.

**Installation:**  
 Wire brush the conductor prior to insertion. The conductor size must be within the specified ranges noted above. Once inserted, tighten bolt to the specified torque rating.

This drawing contains confidential information that is the property of MacLean Power, L.L.C. ("MacLean"). Use of MacLean's confidential information without MacLean's express written consent is strictly prohibited and may expose you to legal liability. If you believe that you received this material in error, please destroy it or return it to "MacLean Power, L.L.C., 481 Munn Rd, Suite 300, Fort Mill, SC 29715 USA."



DRAWING NUMBER: <b>GD-AVC-3</b>	
SHEET NAME: <b>Sheet1</b>	1 OF 1
DRAWING DESCRIPTION: <b>AVC-3</b>	
DRAWN BY: AR	DESIGN DATE: 11-17-17