

A | B | C | D | E | F

PAPER SIZE		DRAWING NUMBER	
B	SIZE	GD-J25248.1	
REV	REVISION DATE	ECO	
A	06-29-12	10655	
B	08-07-12	10683	

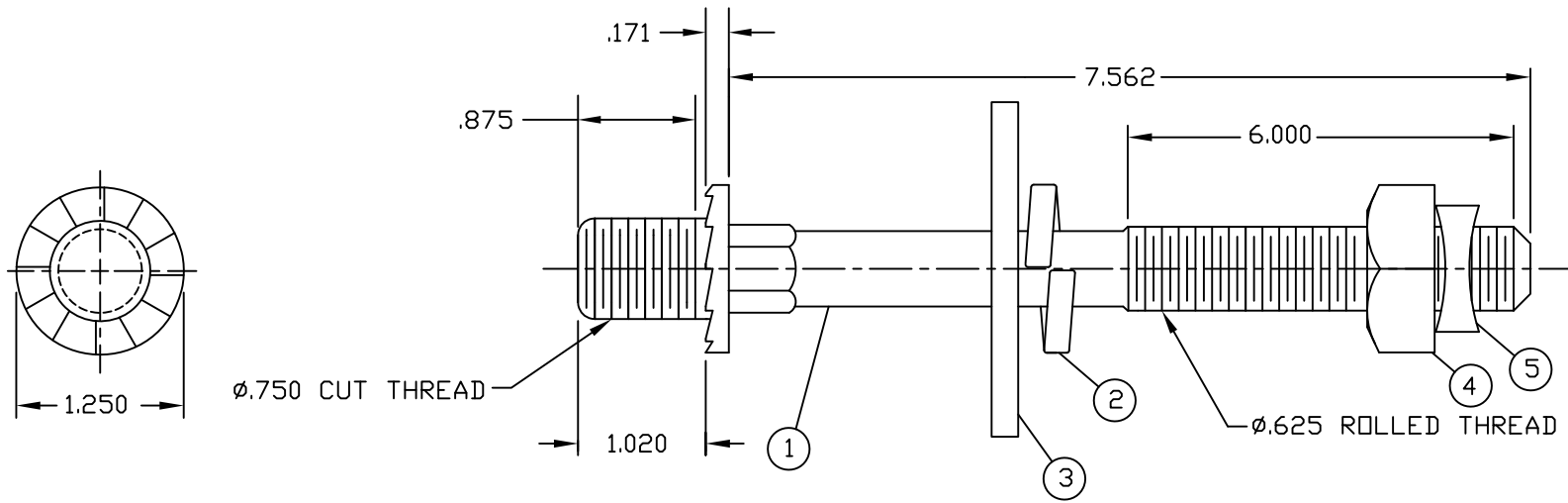

TABLE 1

ITEM	QTY	DESCRIPTION
1	1	LINE POST STUD
2	2	.750 SPRING LOCKWASHER
3	1	2.250 SQUARE WASHER
4	1	.625 SQUARE NUT
5	1	.625 M-F LOCKNUT

NOTES:

- 1) MATERIAL: HOT ROLLED CARBON STEEL
- 2) ALL DIMENSIONS ARE REFERENCE AND ARE IN INCHES.
- 3) ALL ITEMS ARE HOT DIP GALVANIZED PER ASTM A-153.
- 4) ADDITIONAL HARDWARE (ITEMS 2, 3, 4 AND 5) TO BE ASSEMBLED WITH THE LINE POST STUD (ITEM 1) AS SHOWN IN TABLE 1.

PART NO: F500134

This drawing contains confidential information that is the property of MacLean Power, L.L.C. ("MacLean"). Use of MacLean's confidential information without MacLean's express written consent is strictly prohibited and may expose you to legal liability. If you believe that you received this material in error, please destroy it or return it to "MacLean Power, L.L.C., 11411 Addison, Franklin Park, Illinois 60131, USA."

DRAWING-COMPUTER LOCATION

TOLERANCES UNLESS SPECIFIED	
inches	
0.XX	----
0.XXX	----
ANGLE	----



DRAWN BY	ENGINEER	CHECKER	CATALOG #	SCALE	DESIGN DATE
PDR	RRL	JBB	J25248.1	NTS	06-29-12
DRAWING TITLE / DESCRIPTION					DRAWING NUMBER
5/8" LINE POST STUD LONG SHANK ASSEMBLY					GD-J25248.1