

A | B | C | D | E | F

PAPER SIZE	DRAWING NUMBER	
B SIZE	GD-J607Z-DE	
REV	REVISION DATE	ECO
A	7-17-17	D8627

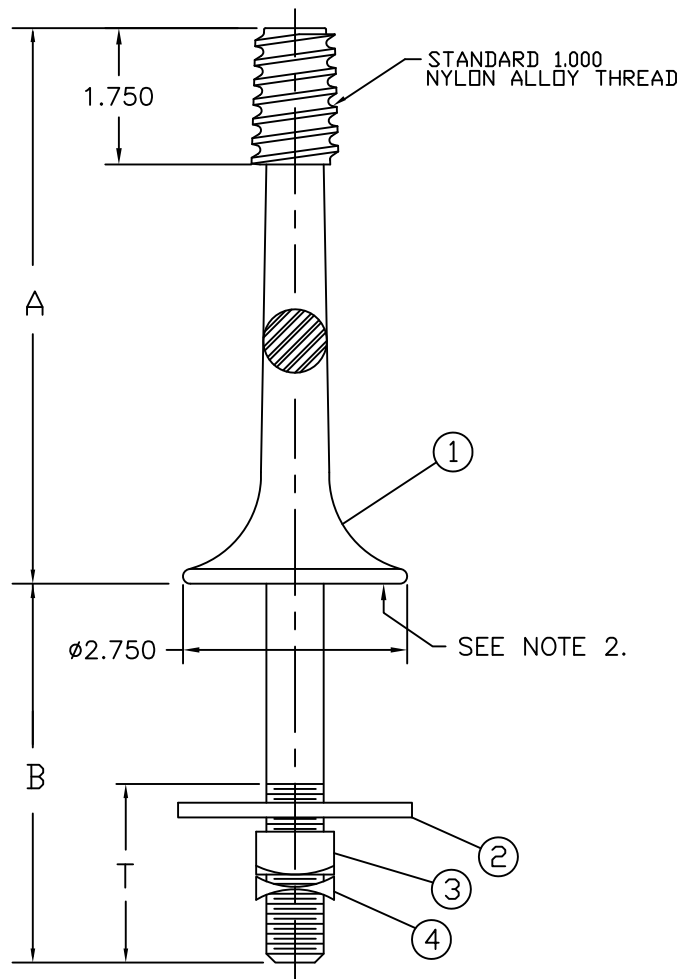

MATERIAL:
 THREAD: NYLON ALLOY
 PIN: FORGED STEEL GALVANIZED PER ASTM A-153

- NOTES:**
1. ALL DIMENSIONS ARE REFERENCE AND IN INCHES EXCEPT AS NOTED.
 2. MANUFACTURER'S IDENTIFICATION MARK ("J" STAMP) AND YEAR OF MANUFACTURE (example "07") IN LOCATION SHOWN.

ITEM	QTY	DESCRIPTION
1	1	STEEL PIN BODY
2	1	3.00 SQ X .187 SQUARE WASHER
3	1	.75 REGULAR SQUARE NUT
4	1	.75 SQUARE M-F LOCKNUT

CATALOG NO.	A	B	T
J607Z-DE	7.000	8.000	5.000

TOLERANCES UNLESS SPECIFIED	
INCH	
0.XX	----
0.XXX	----
ANGLE	----



DRAWN BY	ENGINEER	CHECKER	CATALOG #	SCALE	DESIGN DATE
MB	MB	MG	J607Z-DE	NTS	05-27-03
DRAWING TITLE / DESCRIPTION					DRAWING NUMBER
PIN X ARM W/NA THD					GD-J607Z-DE

DRAWING-COMPUTER LOCATION

This drawing contains confidential information that is the property of MacLean Power, L.L.C. ("MacLean"). Use of MacLean's confidential information without MacLean's express written consent is strictly prohibited and may expose you to legal liability. If you believe that you received this material in error, please destroy it or return it to "MacLean Power, L.L.C., 11411 Addison, Franklin Park, Illinois 60131, USA."