

8 7 6 5 4 3 2 1

PAPER SIZE		DRAWING NUMBER	
<b>B</b>		<b>GD-J8702</b>	
REV	REVISED BY	REVISION DATE	ECO #
A	PDR	10-01-12	10722

D  
C  
B  
A

D  
C  
B  
A

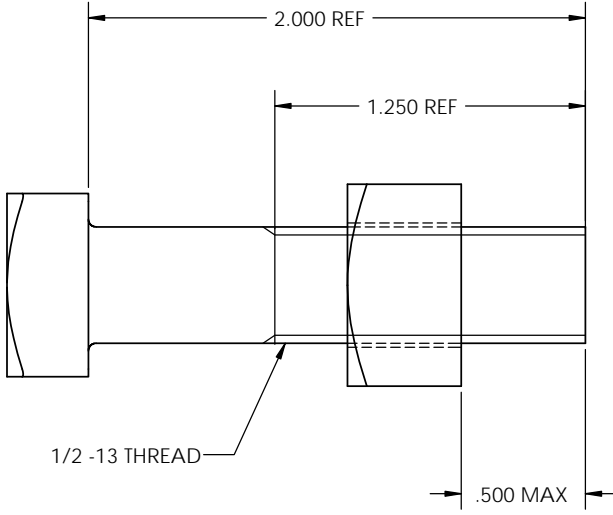
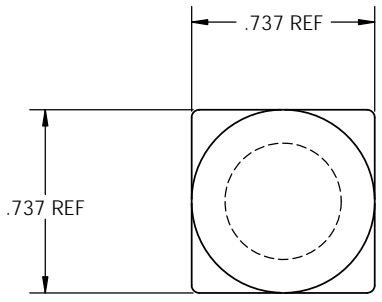

- NOTES:**
1. MATERIAL: HOT ROLLED CARBON STEEL
  2. ALL DIMENSIONS ARE REFERENCE AND ARE IN INCHES.
  3. ALL ITEMS ARE HOT DIP GALVANIZED PER ASTM A153.
  4. MINIMUM TENSILE STRENGTH: 8500 LBS.

PART NO. F614927

This drawing contains confidential information that is the property of MacLean Power, L.L.C. ("MacLean"). Use of MacLean's confidential information without MacLean's express written consent is strictly prohibited and may expose you to legal liability. If you believe that you received this material in error, please destroy it or return it to "MacLean Power, L.L.C., 11411 Addison Street, Franklin Park, Illinois 60131, USA."

UNLESS OTHERWISE SPECIFIED DIMENSIONS ARE IN:	
<b>INCHES</b>	
TOLERANCES ARE:	
XX	+/- .XX
.XXX	+/- .XXX
X/XX	+/- X/XX
ANGLES	+/- .XXX

CATALOG NO. J8702

**MACLEAN  
POWER  
SYSTEMS**

11411 ADDISON STREET  
FRANKLIN PARK, IL 60131

TEL (847) 455-0014 FAX: (847) 455-0029

DRAWING NUMBER: <b>GD-J8702</b>		DO NOT SCALE DRAWING	
SHEET NAME: Sheet1		1 OF 1	
DRAWING DESCRIPTION: BOLT MACH 1/2 X 2		CAD GENERATED DRAWING DO NOT MANUALLY UPDATE	
DRAWING SCALE: 2:1		DESIGN DATE: 10-01-12	
DRAWN BY: PDR		ENGINEER: RRL	
APPROVED: JBB			

8 7 6 5 4 3 2 1