

8 7 6 5 4 3 2 1

PAPER SIZE		DRAWING NUMBER	
B		GD-J9408	
REV	REVISED BY	REVISION DATE	ECO #
A	RC	07/30/09	9597
B	PDR	08/07/12	10683

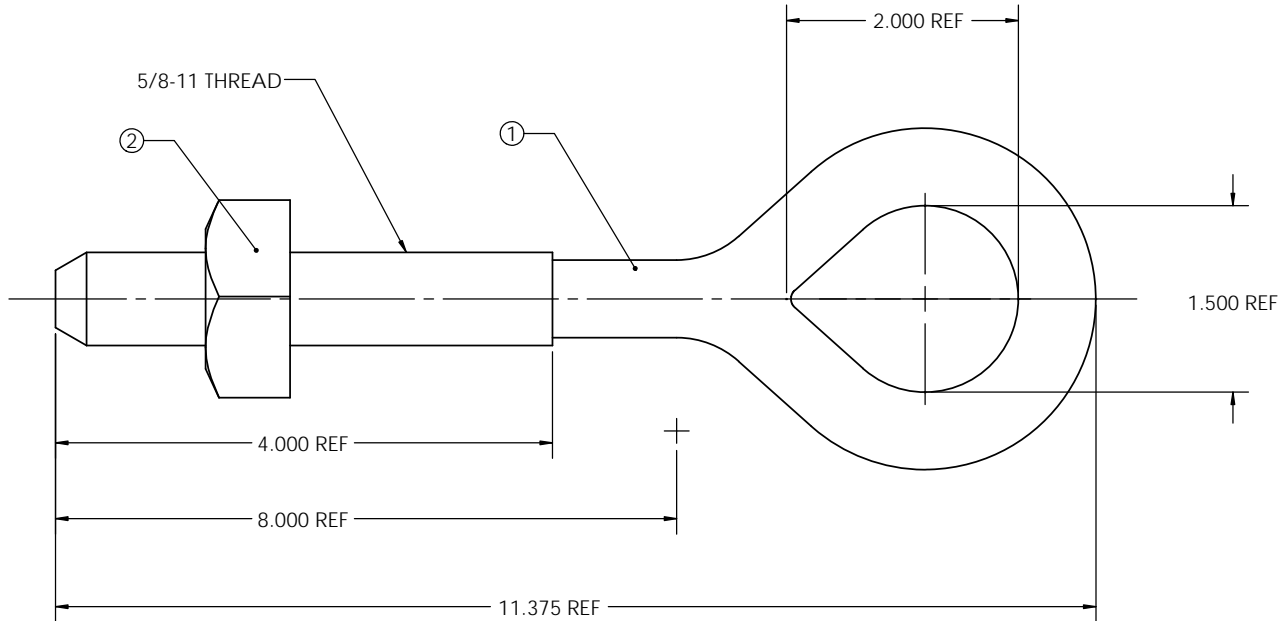

- NOTES:**
1. MATERIAL: HOT ROLLED CARBON STEEL
 2. ALL DIMENSIONS ARE REFERENCE AND ARE IN INCHES.
 3. ALL ITEMS ARE HOT DIP GALVANIZED PER ASTM A153.
 4. MINIMUM TENSILE STRENGTH: 13,550 LBS.

ITEM	QTY	DESCRIPTION
1	1	BOLT OVAL EYE 5/8
2	1	NUT SQUARE 5/8

This drawing contains confidential information that is the property of MacLean Power, L.L.C. ("MacLean"). Use of MacLean's confidential information without MacLean's express written consent is strictly prohibited and may expose you to legal liability. If you believe that you received this material in error, please destroy it or return it to "MacLean Power, L.L.C., 11411 Addison Street, Franklin Park, Illinois 60131, "USA."

UNLESS OTHERWISE SPECIFIED DIMENSIONS ARE IN:	
INCHES	
TOLERANCES ARE:	
XX	+/- .XX
.XXX	+/- .XXX
X/XX	+/- X/XX
ANGLES	+/- .XXX

CATALOG NO. J9408

**MACLEAN
POWER
SYSTEMS**

11411 ADDISON STREET
FRANKLIN PARK, IL 60131
TEL: (847) 455-0014 FAX: (847) 455-0029

PART NO. F614832		DRAWING NUMBER:		DO NOT SCALE DRAWING	
		GD-J9408		CAD GENERATED DRAWING DO NOT MANUALLY UPDATE	
SHEET NAME:		1 OF 1		DESIGN DATE: 07/30/09	
DRAWING DESCRIPTION:		BOLT OVAL EYE 5/8 X 8		DRAWN BY: RC	
				ENGINEER: DEK	
				APPROVED: FJS	
DRAWING SCALE: NTS					

8 7 6 5 4 3 2 1