

ITEM	DESCRIPTION	MATERIAL	QTY
1	PTS/DCP GROUNDING CLAMP BODY 25MM BALL STUD MAIN TO 4/0 MAXIMUM TAP WIRE	C95400 BRONZE ALLOY	1
2	BALL STUD CLAMP'S KEEPER	BRONZE C-85500	1
3	MONOBLOC EYE SCREW	C95600 CU/AL ALLOY	1
4	#10 PUSH NUT	GALVANIZED STEEL	1
5	#10-24 SCREW, 3/8 LENGTH	STAINLESS STEEL	1
6	YELLOW PLASTIC CAPPLUGS Ø0,145"	PLASTIC	1

PART NUMBER  
F612655  
DRAWING NUMBER  
HC-10015-A  
FORMAT  
A

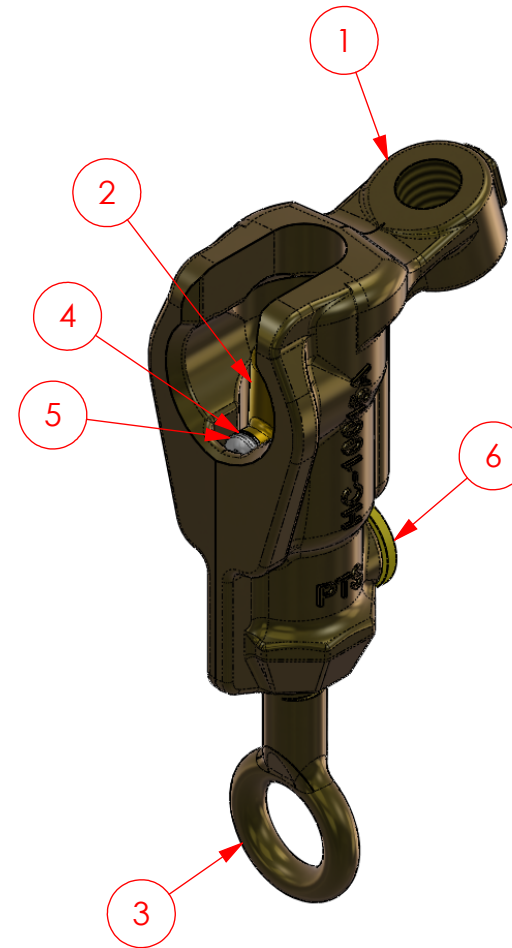

This drawing contains confidential information that is the property of MacLean Power Systems Canada. Use of MacLean's confidential information without MacLean's express written consent is strictly prohibited and may expose you to legal liability. If you believe that you received this material in error, please destroy it or return it to MacLean Power Systems Canada, 225 Ford, Chateauguay (Québec), Canada, J6J 4Z2

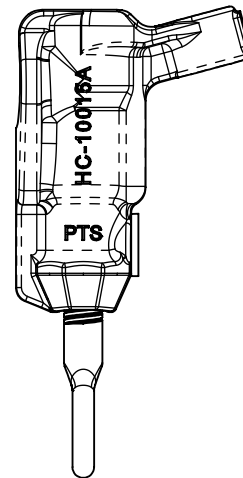
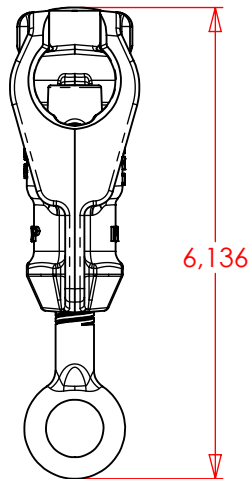
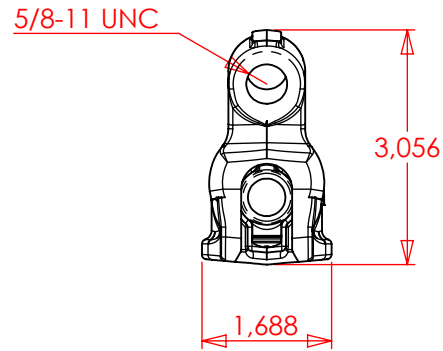

225 Ford, Châteauguay (Qué.) Canada J6J 4Z2  
Tel. (450) 698-0520 Fax: (450) 692-5670

DESCRIPTION  
25MM GROUNDING CLAMP

PROJECT NUMBER

SAP:

PAGE

1 of 1

PART NUMBER

F612655

PRODUCT NUMBER

HC-10015-A

DRAWING NUMBER

HC-10015-A